

➤ Instructions

Thule Basin Wedge

901018



EN Roof mounted tent for car load carrier.
FR Tente montée sur toit pour barres de toit.
ES Tienda de montaje en techo para portaequipajes de vehículos.
DE Dachzelt zur Montage auf dem Dachträger des Autos.
NL Tent voor op het dak van een auto met een allesdrager.
PT Barraca de teto para racks Automotivos
IT Tenda da tetto per portapacchi per auto.
SV Takmonterat tält för lasthållare.
DK Tagmonteret lastholder til biltelt.
NO Takmontert telt for lasteholder for bil.
FI Katolle kiinnitettävä telttä auton taakkatelineelle.
IS Þakfest tjald fyrir farangursgrind á bíl.
ET Katusele paigaldatav auto katuseraami telk.
LV Uz automašīnas jumta kravas bagāžnieka uzstādāma telts.
LT Ant stogo tvirtinamas tentas, skirtas automobilio krovinių laikikliui.
RU Палатка, монтируемая на верхнем багажнике автомобиля.
UK Намет із кріпленням на даху для багажника автомобіля.
PL Namiot mocowany do bagażnika montowanego na dachu.
CS Střešní stan pro střešní nosič auta.
HU Tetőcsomagtartóra szerelhető sátor.
RO Cort montat pe acoperiș pentru suportul de transport al automobilului.
SK Strešný stan s upevnením na strešný nosič
SL Strešni šotor za strešni prtljažnik.

BG Монтирана върху покрива шатра за багажник.
HR Krovni nosač tereta za šator koji se postavlja na krov automobila.
EL Τέντα στερέωσης στην οροφή για σχάρα αυτοκινητού.
TR Araç yük taşıyıcısı için, araç üstüne monte edilen çadır.
MT Tinda għall-ġarrier ta' tagħbija mmuntat fuq is-saqaf ta' karozza.
HE אוהל להתקנה על הגג עבור מנשא מטען למכונית.
AR خيمة محمولة على السقف لحاملة السيارات

ZH (CN) 用于汽车货物托架的顶置式帐篷。
ZH (TW) 汽車荷重支架用車頂帳。
JA カーロードキャリア用ルーフマウントテント。
KO 차량 화물 캐리어용 루프 장착 텐트
TH เต็นท์ติดหลังคาสำหรับที่ใส่สัมภาระบนหลังคารถ
MS Khemah yang dipasang pada bumbung untuk pengangkut muatan kereta.

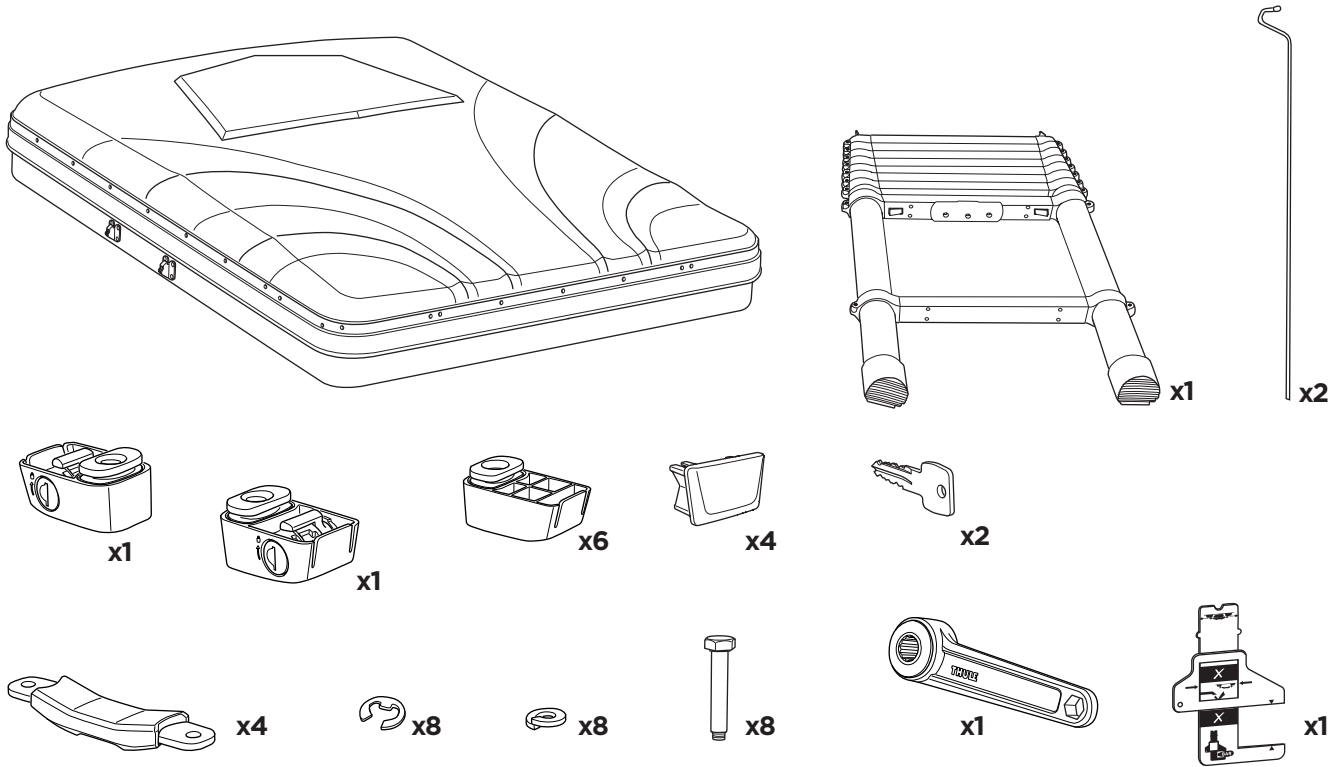
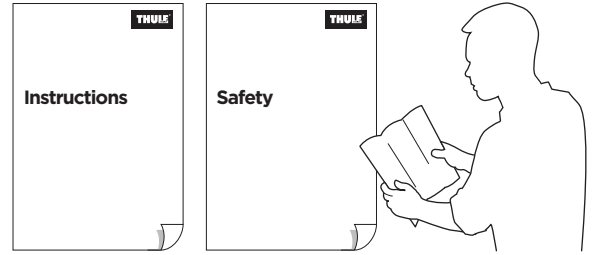

> Video Instructions
 Thule Basin Wedge



www.thule.com

> Video Instructions
 Thule Mounting Bracket



www.thule.com

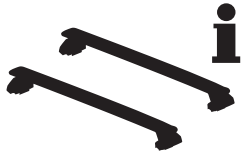

4-6

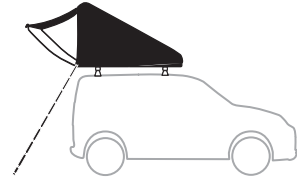

17-21

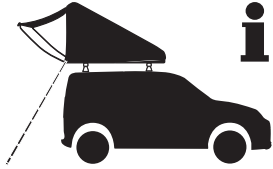

7-8



22

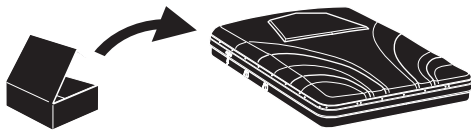

9-10

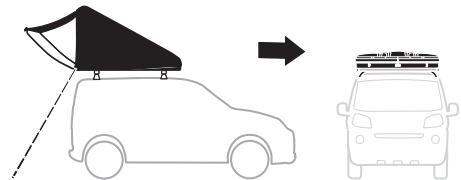

23-25

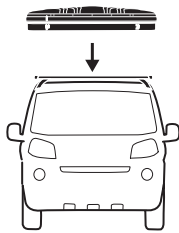

11-14

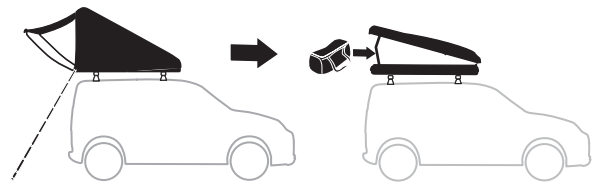

26-28

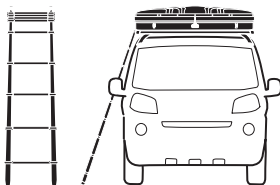

15-16

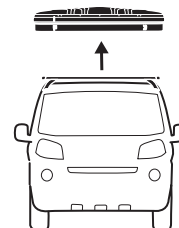

29

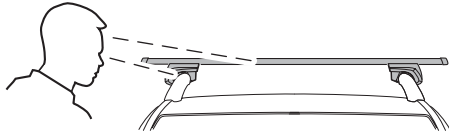

THULE SlideBar Evo



THULE WingBar Evo

THULE AeroBlade

THULE ProBar Evo

THULE SquareBar Evo

THULE Xsporter

THULE TracRac

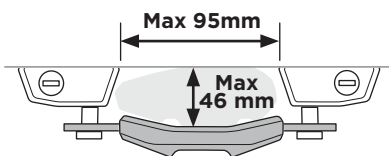
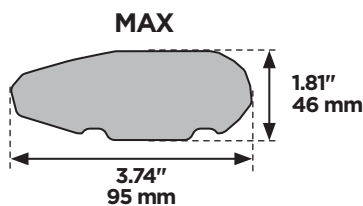

Not ok

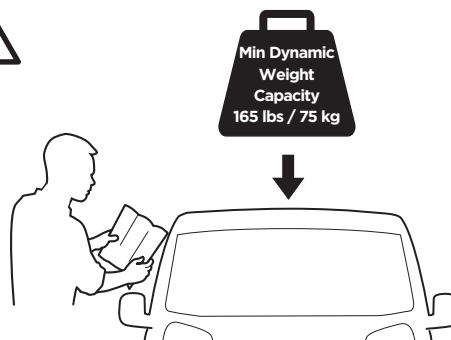
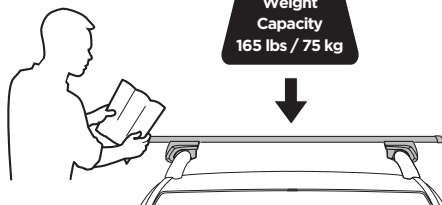
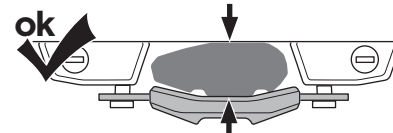
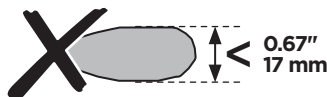
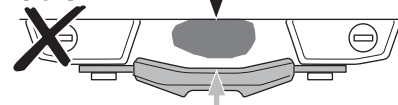

Weight capacity of tent in use with people inside the tent (static weight) can exceed the dynamic (driving) weight capacity. The tent's static weight capacity is 300 kg/ 600 lbs

Recommended roof rack weight capacities can be found on Thule.com. Check your vehicle instruction booklet for information on recommended roof load.

Thule only recommends Thule roof rack systems for Thule rooftop tents. For other brand roof rack applications check vehicle and roof rack owner's manual for maximum weight capacity. Thule cannot guarantee any compatibility of other roof racks and/or their load capabilities.

La capacité de poids de la tente en usage avec des personnes à l'intérieur de la tente (poids statique) peut dépasser la capacité de poids dynamique (de conduite). La capacité de poids statique de la tente est de 300 kg/ 600 lbs.

Les capacités de poids recommandées pour les barres de toit sont disponibles sur Thule.com. Veuillez consulter le manuel d'instructions de votre véhicule pour obtenir la charge recommandée.

Thule recommande uniquement les systèmes de support de toit Thule pour les tentes de toit Thule. Pour les applications touchant d'autres marques de supports de toit, consultez le manuel du propriétaire du véhicule ou du support de toit pour connaître la capacité de poids maximale. Thule ne peut pas garantir la compatibilité des autres supports de toit ni leurs capacités de charge.

Die Tragfähigkeit des Zelts, wenn es in Gebrauch ist und sich Personen darin befinden (statische Tragfähigkeit), kann die dynamische Tragfähigkeit (in Fahrt) überschreiten. Die statische Tragfähigkeit ist 300 kg / 600 lbs.

Empfohlene Gewichtskapazitäten für Dachträger finden Sie auf Thule.com. Überprüfen Sie die Betriebsanleitung Ihres Fahrzeugs auf Informationen zur empfohlenen Dachlast.

Thule empfiehlt für Thule Dachzelte nur Thule Dachträgersysteme. Bei Dachträgern anderer Marken überprüfen Sie bitte das Benutzerhandbuch des Fahrzeugs und des Dachträgers auf die maximale Tragfähigkeit. Thule garantiert keine Kompatibilität mit anderen Dachträgern und/oder deren Tragfähigkeit.

La capacidad de peso de la tienda en uso con personas dentro de la tienda (peso estático) puede exceder la capacidad de peso dinámico (en movimiento). La capacidad de peso estático de la tienda es 300 kg / 600 lbs.

En Thule.com podrá encontrar las capacidades de peso recomendadas de las barras de techo. Consulte el folleto de instrucciones de su vehículo para obtener información sobre la carga de techo recomendada.

Thule solo recomienda los sistemas de barras de techo Thule para las tiendas de techo Thule. Para su uso con barras de techo de otras marcas, consulte el manual del vehículo y del fabricante de las barras de techo para conocer la capacidad de peso máxima. Thule no puede garantizar la compatibilidad de otras barras de techo ni su capacidad de carga.

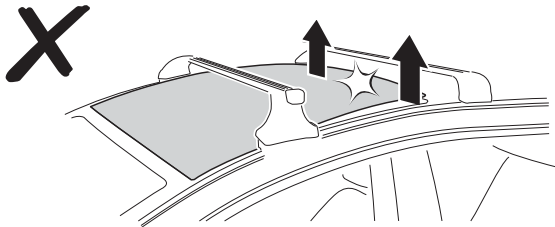
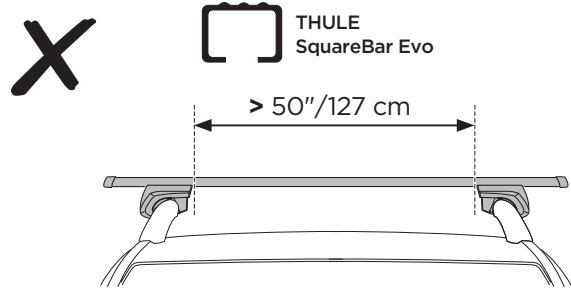
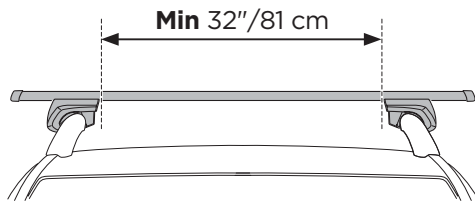
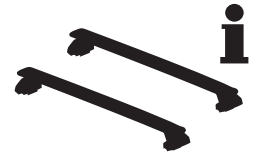

DO NOT use Thule rooftop tents with vehicles with glass roofs. **EN**
Cars with sunroofs may be used but the opening function should not be used.

N'utilisez PAS de tentes Thule avec des véhicules avec un toit vitré. Il est possible d'utiliser la tente sur un véhicule doté d'un toit ouvrant sans ouvrir ce dernier. **FR**

Benutzen Sie Thule Zelte NICHT auf Fahrzeugen mit Glasdächern. Der Einsatz auf Autos mit Schiebedach ist möglich, die Öffnungsfunktion darf jedoch nicht genutzt werden. **DE**

NO utilice tiendas Thule con cualquier tipo de vehículo con techo de cristal. Se pueden usar automóviles con techos corredizos, pero no se debe usar la función de abertura. **ES**

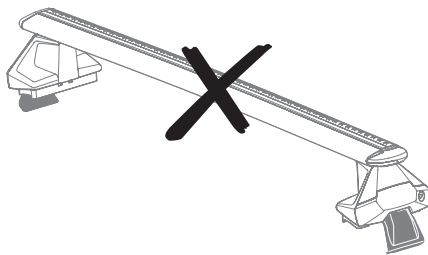

Do not use Thule tents with any type of Thule Clamp style roof rack as the high static weight may cause damage to your car's roof. **EN**

N'utilisez PAS les tentes avec un support de toit à serrage breveté étant donné que le poids statique élevé risque d'endommager le toit. **FR**

Benutzen Sie Thule Zelte NICHT mit Klammer-Dachträgern jeglicher Ausführung, da das hohe statische Gewicht Schäden am Dach verursachen kann. **DE**

NO utilice tiendas Thule con cualquier tipo de barra de techo de las que llevan horquillas, ya que el elevado peso estático podría dañar el techo. **ES**

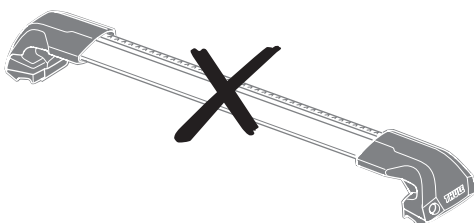

Do not use Thule tents with any type of Thule Edge roof rack as the high static weight may cause damage to your car's roof. **EN**

N'utilisez PAS les tentes avec un support de toit Edge étant donné que le poids statique élevé risque d'endommager le toit. **FR**

Benutzen Sie Thule Zelte NICHT mit Edge-Dachträgern jeglicher Ausführung, da das hohe statische Gewicht Schäden am Dach verursachen kann. **DE**

NO utilice tiendas Thule con cualquier tipo de barra de techo Edge, ya que el elevado peso estático podría dañar el techo. **ES**

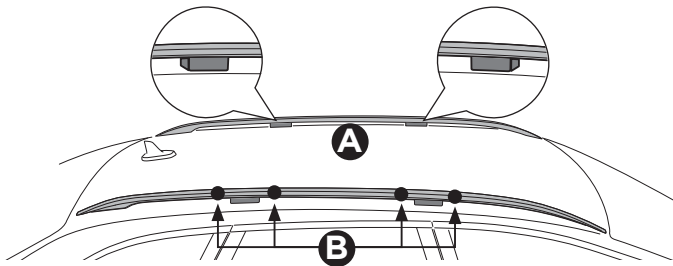
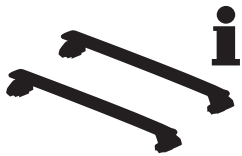

When mounting Thule rooftop tents to vehicles with raised side rails:

EN

- A** Make sure raised rails are structurally supported.
- B** Make sure crossbars are positioned next to supports of raised rails.

Lors du montage d'une tente sur un véhicule doté de rails latéraux surélevés:

FR

- A** Assurez-vous que les rails sont soutenus structurellement.
- B** Assurez-vous que les barres transversales sont maintenues en place à côté des rails surélevés.

Beachten Sie Folgendes bei der Montage von Thule Zelten auf Fahrzeugen mit erhöhten Seitenschienen:

DE

- A** Versichern Sie sich, dass die erhöhten Seitenschienen strukturell gestützt sind.
- B** Versichern Sie sich, dass die Querstreben neben den Stützen der erhöhten Seitenschienen positioniert sind.

Al montar tiendas Thule en vehículos con rieles laterales elevados:

ES

- A** Asegúrese de que los rieles elevados cuenten con un soporte estructural.
- B** Asegúrese de que las barras transversales estén colocadas junto a los soportes de los rieles elevados.

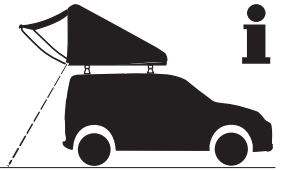

Max 130 km/h
80 Mph

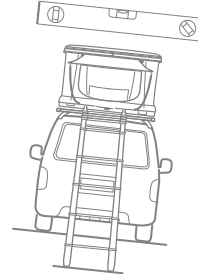
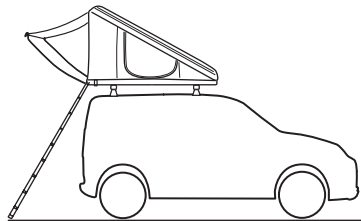
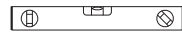
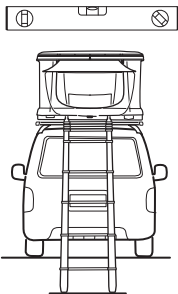
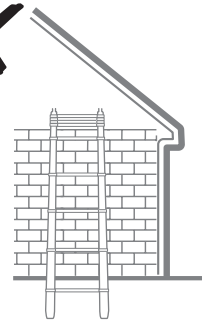
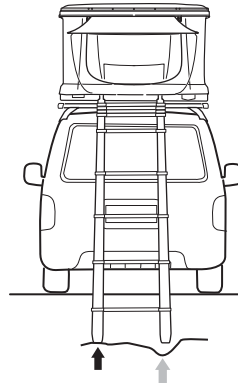
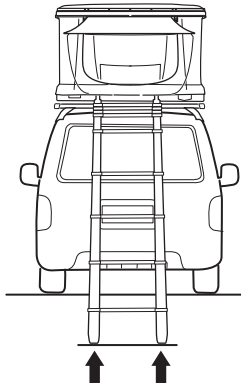
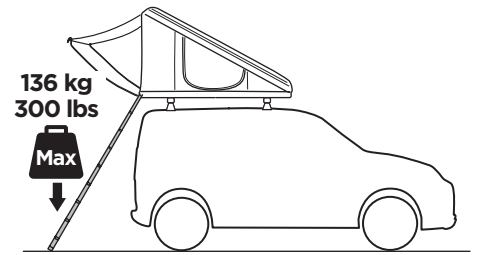
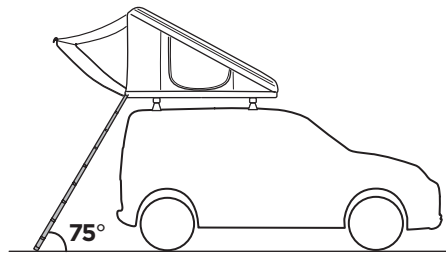
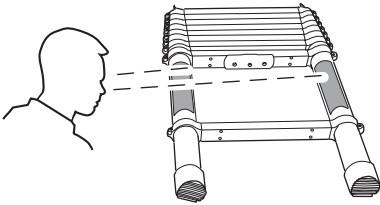
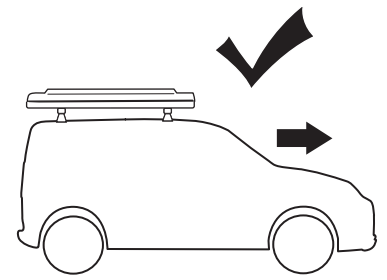
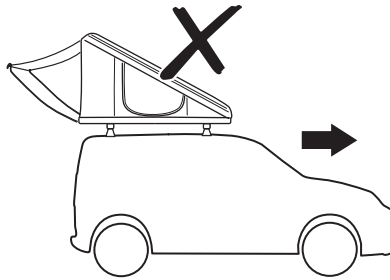
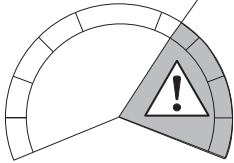

Thule Levelers
307617

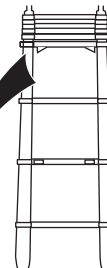
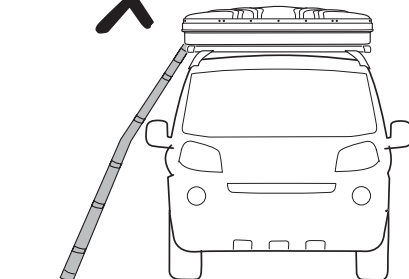
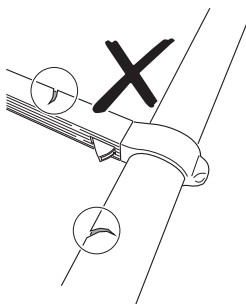
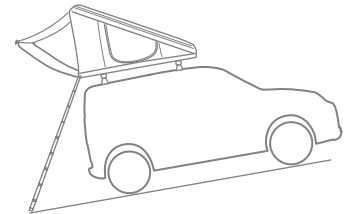

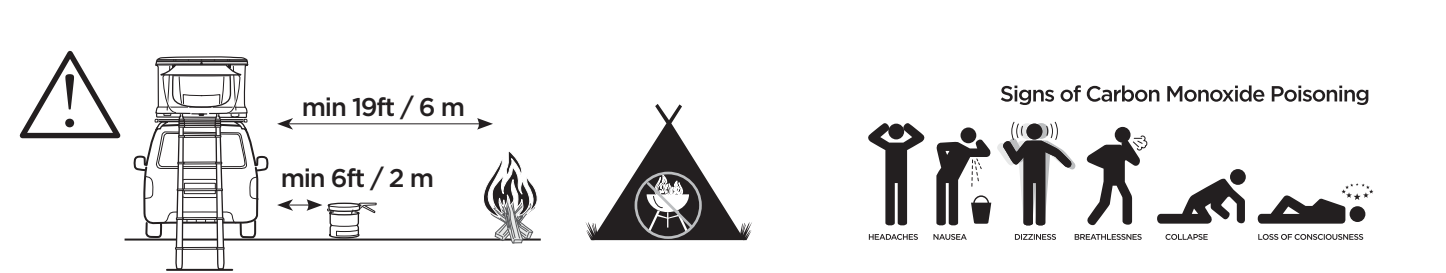
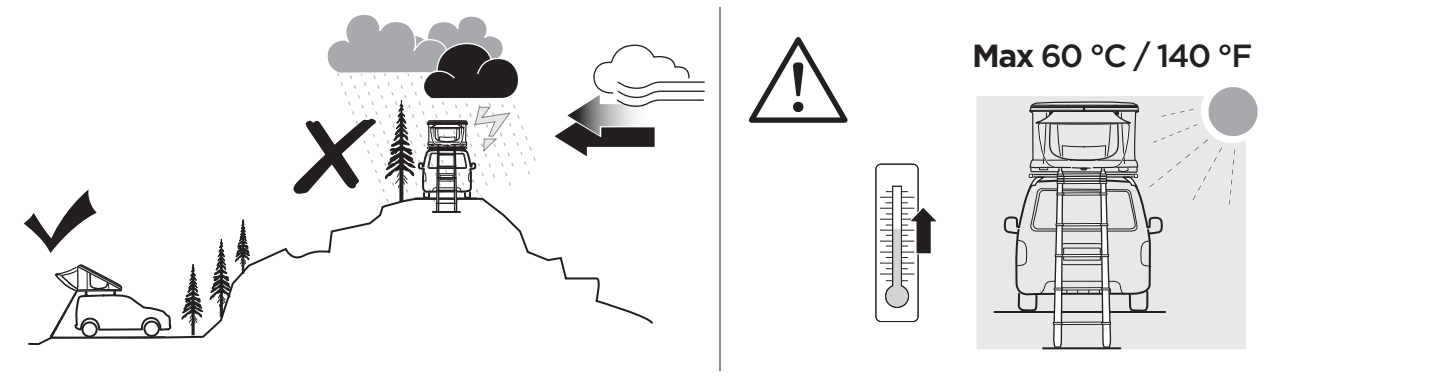
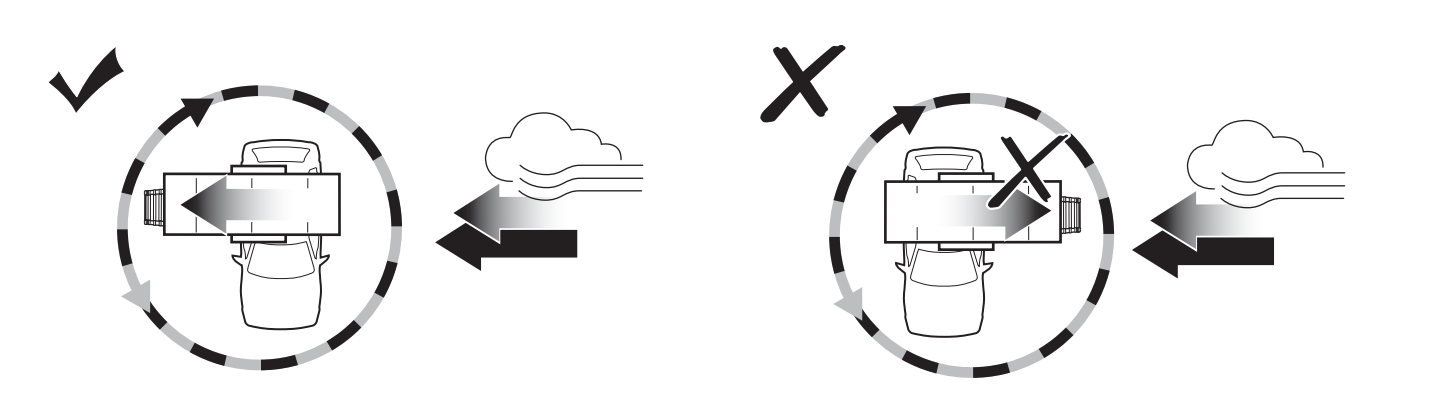
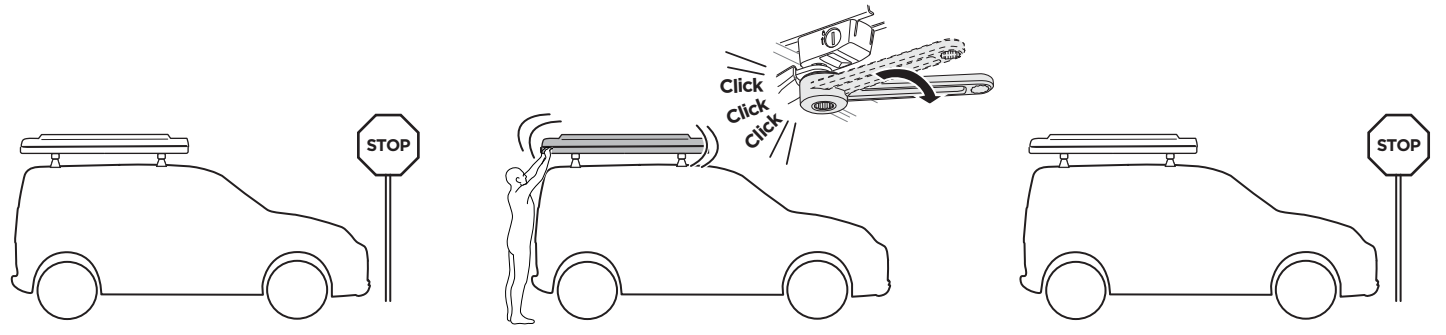
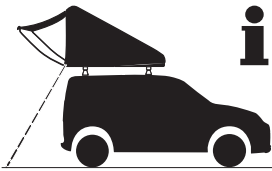

EN

DE

WARNING: KEEP ALL FLAME AND HEAT SOURCES AWAY FROM THIS TENT FABRIC. This tent meets the flammability requirements of CPAI-84. The fabric may burn if left in continuous contact with any flame source. The application of any foreign substance to the tent fabric may render the flameresistant properties ineffective.

WARNUNG: HALTEN SIE ALLE FLAMMEN- UND WÄRMEQUELLEN VON DIESEM ZELTMATERIAL FERN. Dieses Zelt erfüllt die Brandschutzspezifikationen der CPAI-84. Der Stoff kann brennen, wenn er in ständigem Kontakt mit einer Flammenquelle bleibt. Das Aufbringen von Fremdstoffen auf das Zeltmaterial kann die flammenhemmenden Eigenschaften unwirksam machen.

FR

ES

AVERTISSEMENT: CETTE TOILE DE TENTE DOIT ÊTRE TENUE ÉLOIGNÉE DE TOUTES LES SOURCES DE CHALEUR ET FLAMME. Cette tente est conforme aux exigences de la norme CPAI-84 en matière d'inflammabilité. Sa toile peut brûler si elle est maintenue en contact prolongé avec une source de flamme. L'application d'une substance étrangère quelconque sur la toile de la tente peut annuler ses propriétés ignifuges.

ADVERTENCIA: MANTENGA EL TEJIDO DE LA TIENDA ALEJADO DE LAS LLAMAS Y LAS FUENTES DE CALOR. Esta tienda cumple los requisitos de inflamabilidad CPAI-84. El tejido podría arder si entra en contacto continuo con cualquier fuente de fuego. La aplicación de cualquier sustancia extraña al tejido de la tienda podría anular sus propiedades de resistencia al fuego.

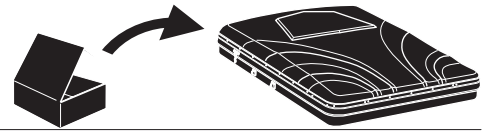

1

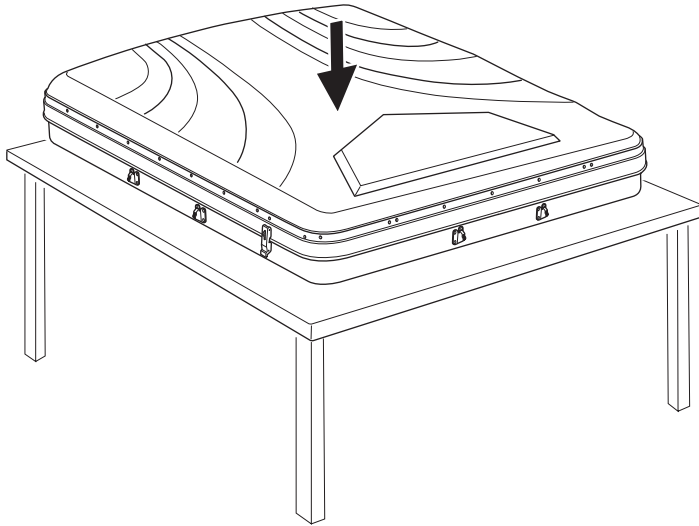

2

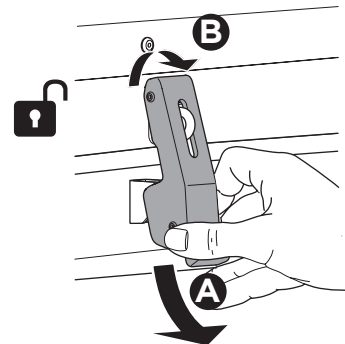
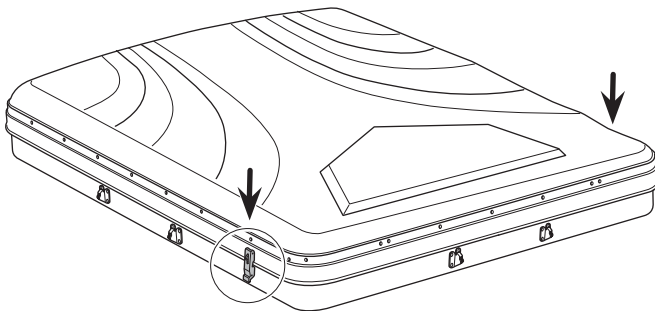

3

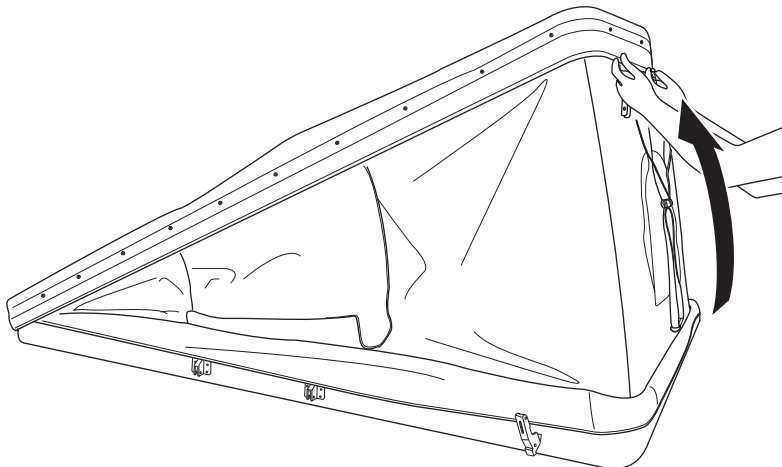

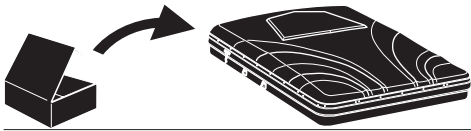

4

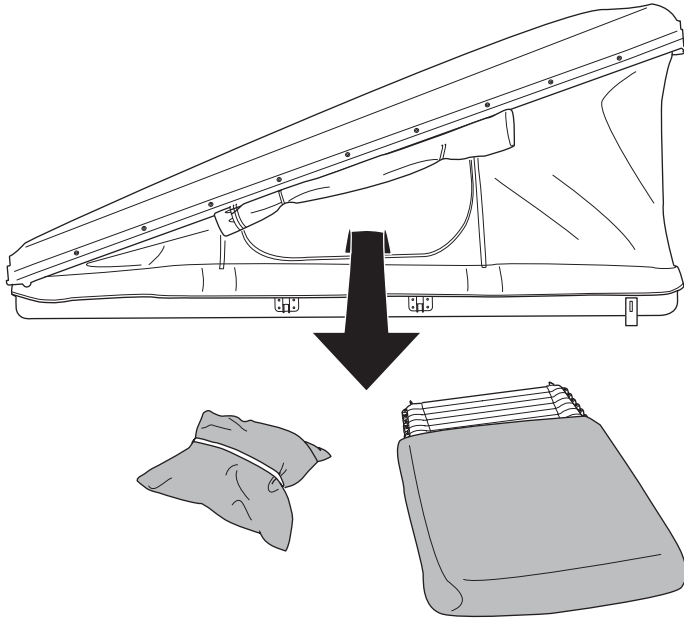

5

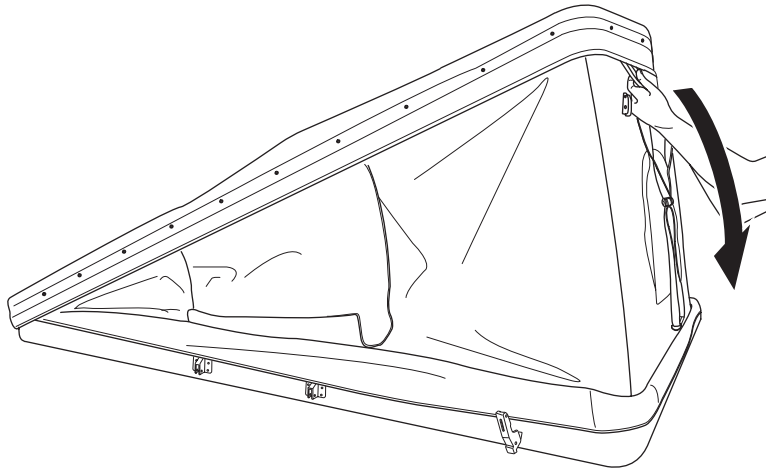

6

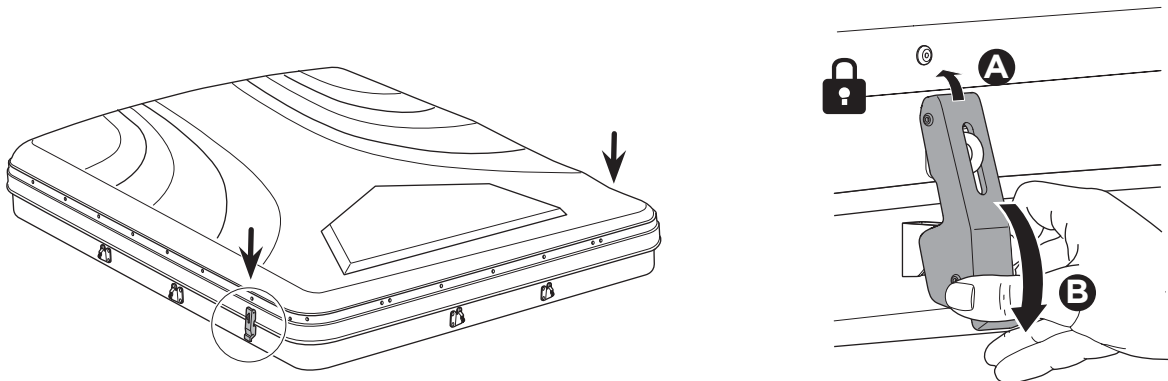

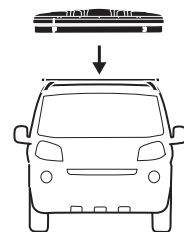

i

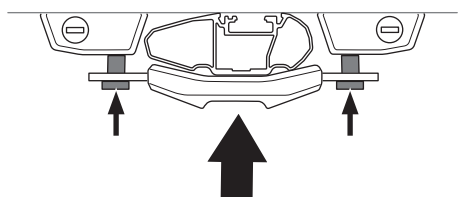

Alt I

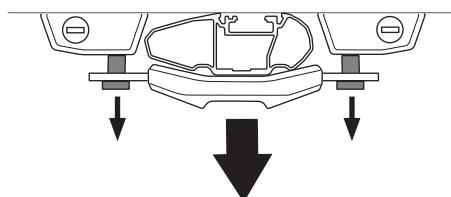
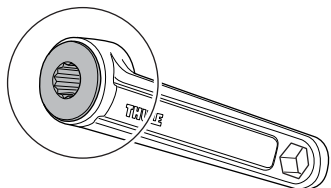

Alt II

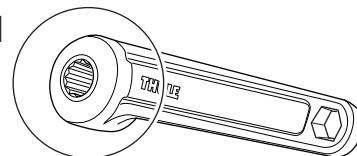

1

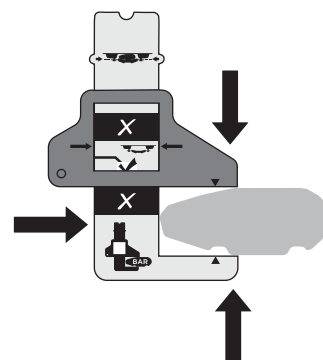
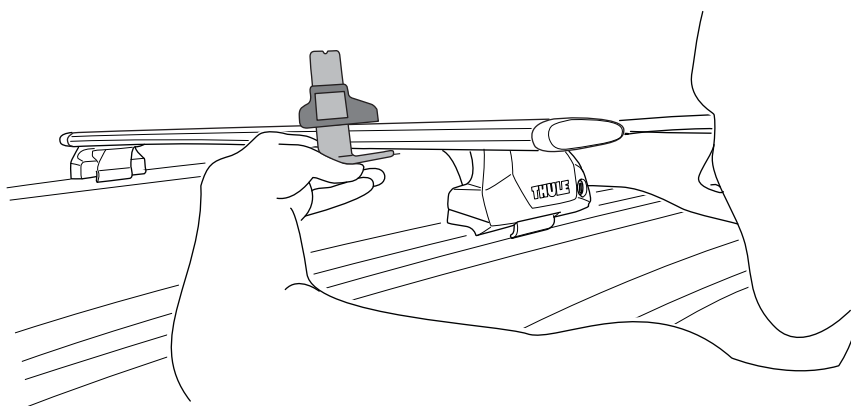

Fit ok

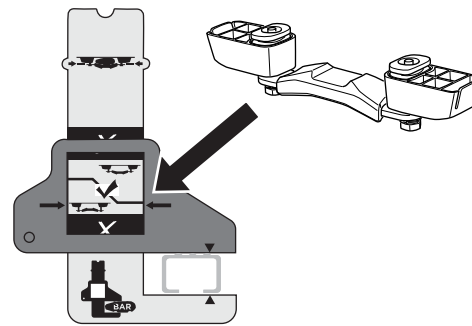
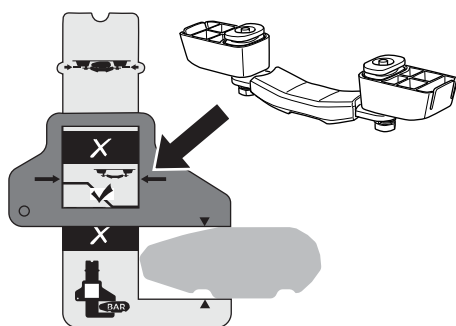

Fit Not ok

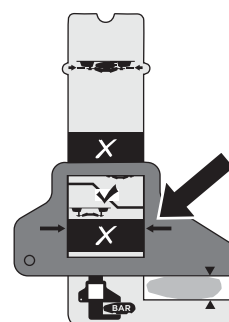
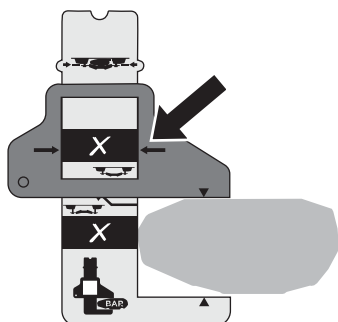

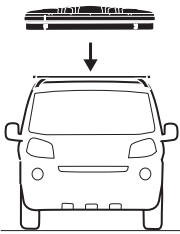

2

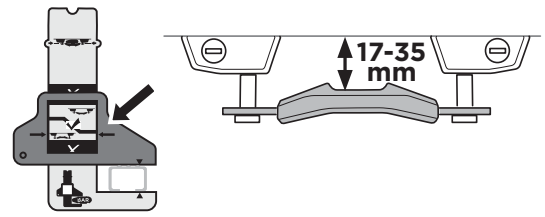
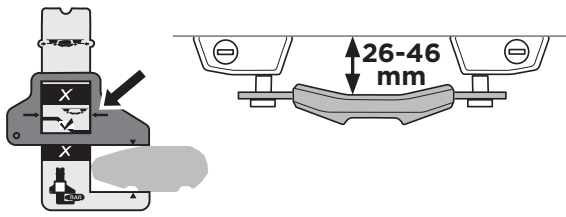

A

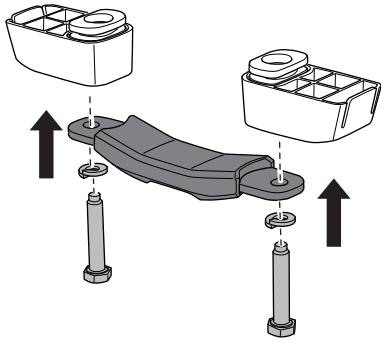

A

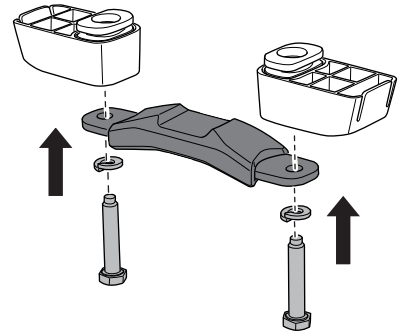

B

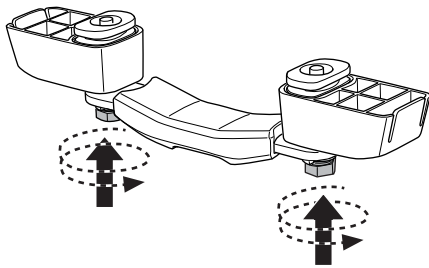

B

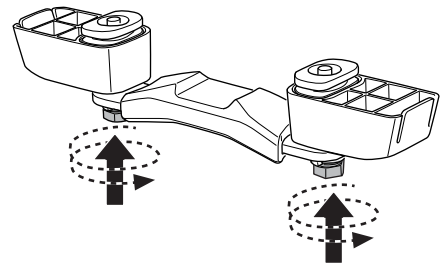

C

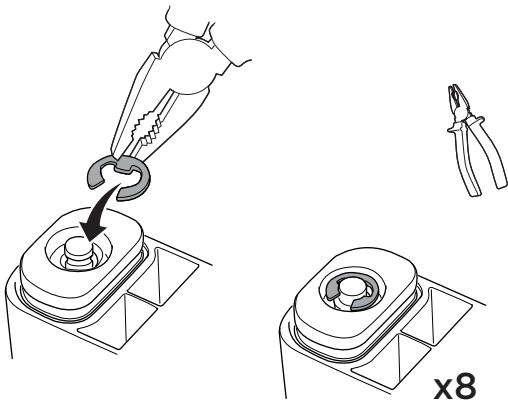

C

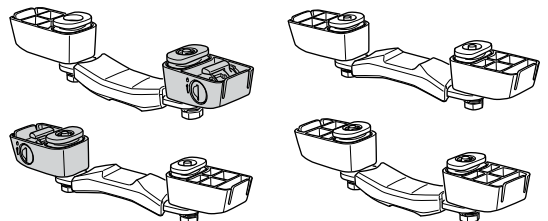
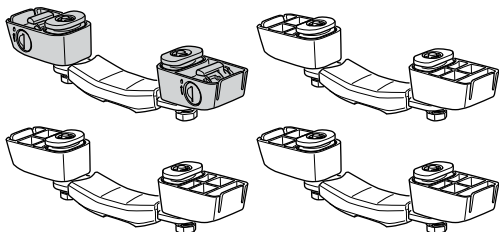
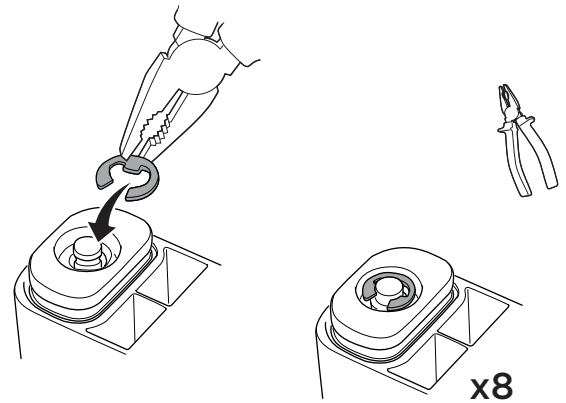

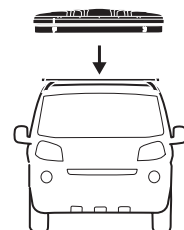

3



4

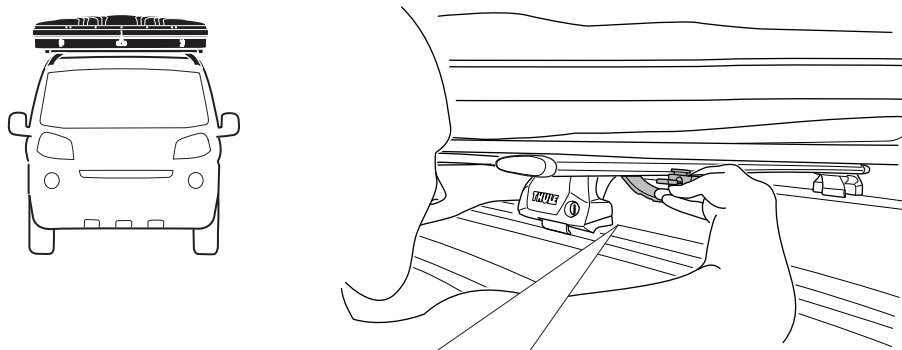

A

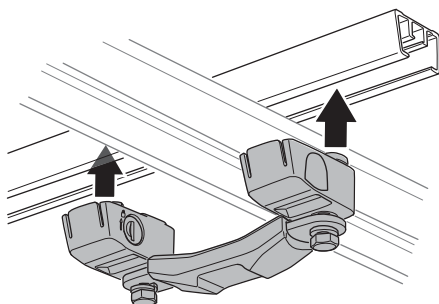

B

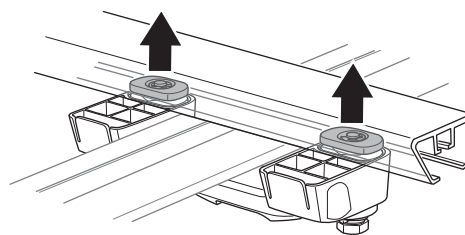

C

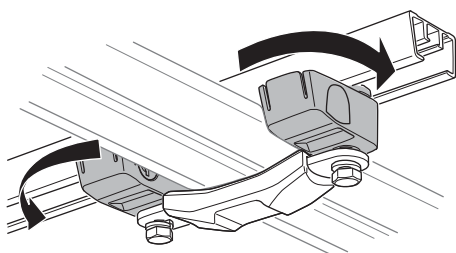

D

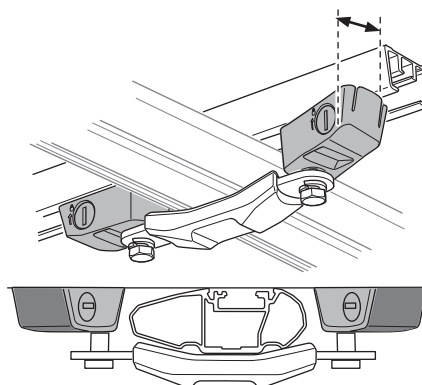
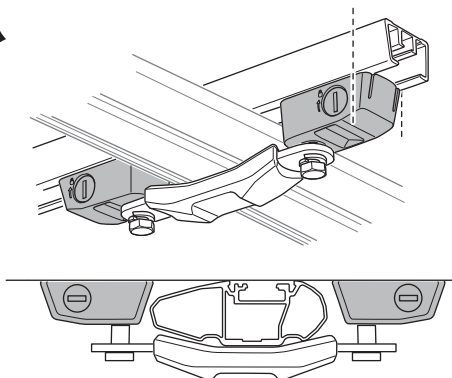
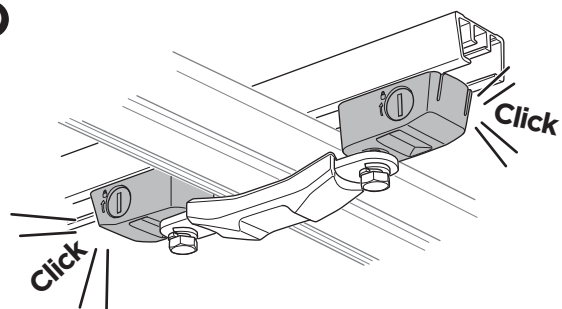

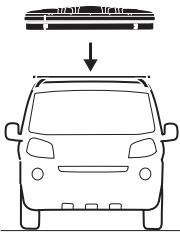

5

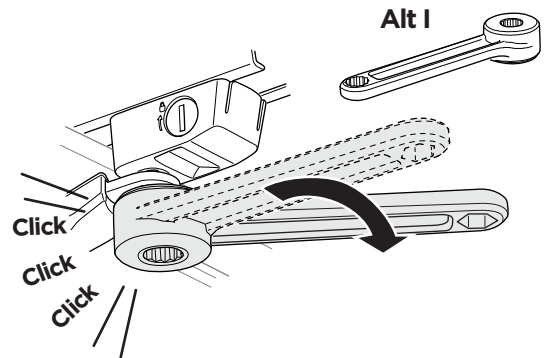
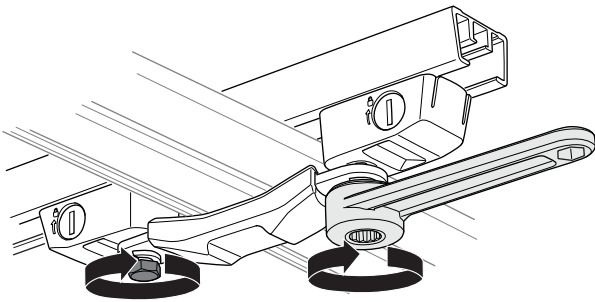
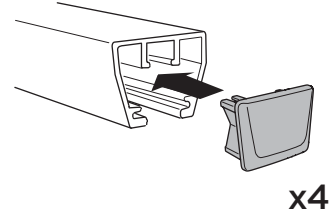
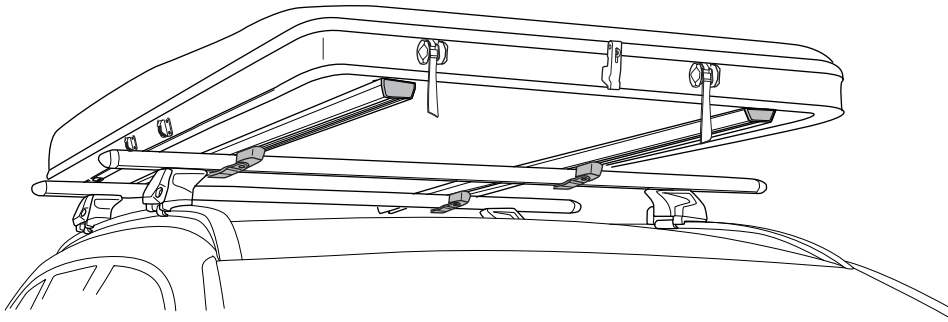

i

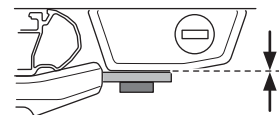
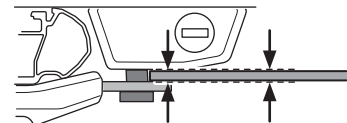
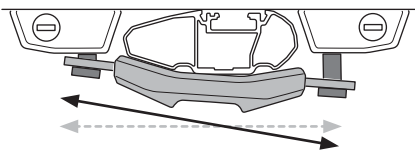
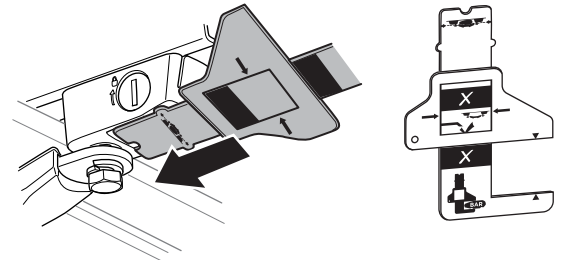
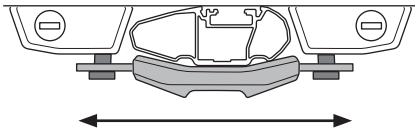

6

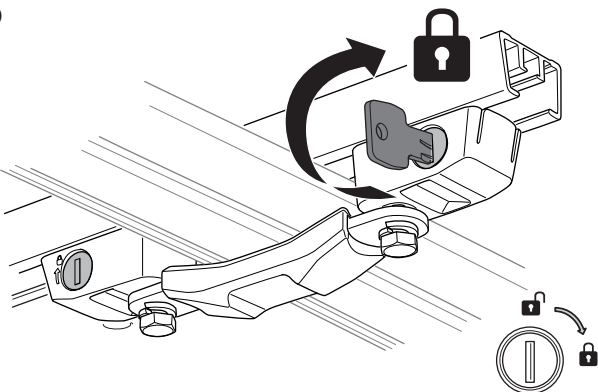

i



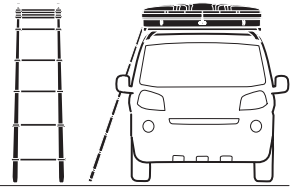

1

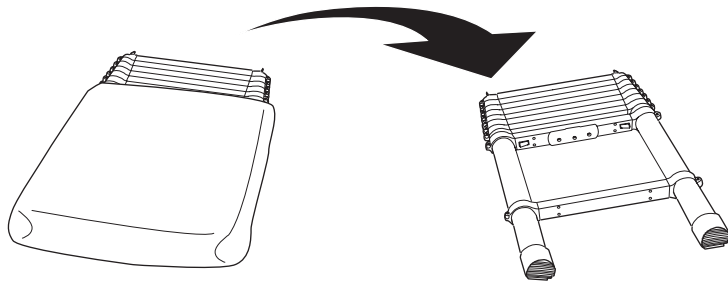

2

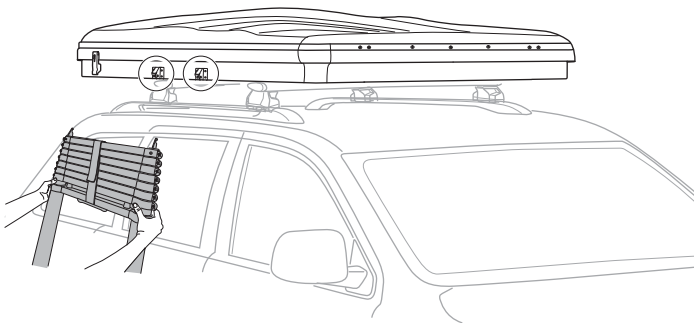

A

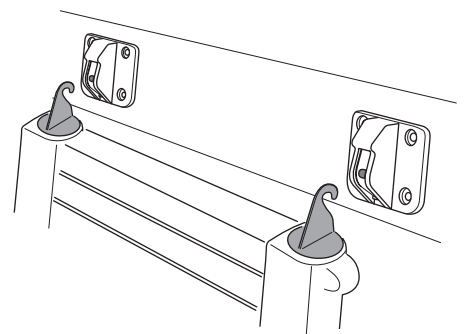

B

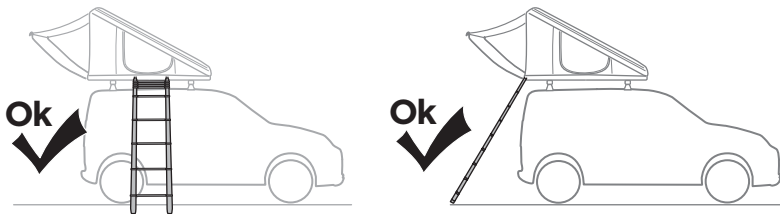
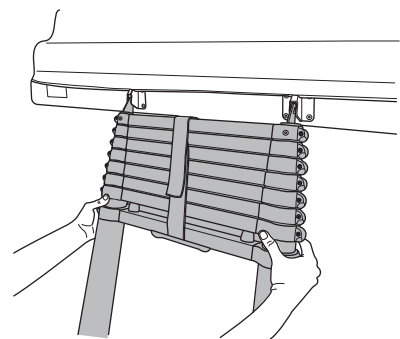

3

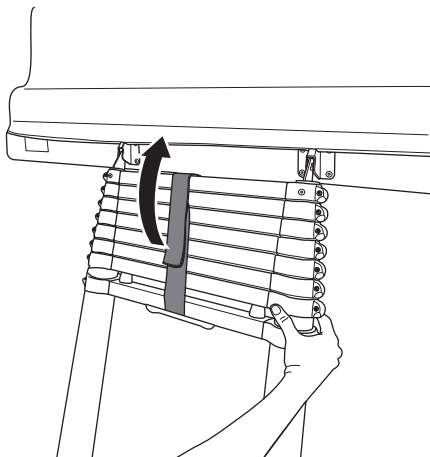

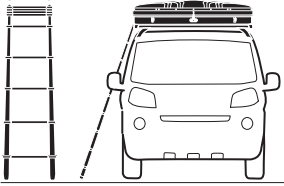

4

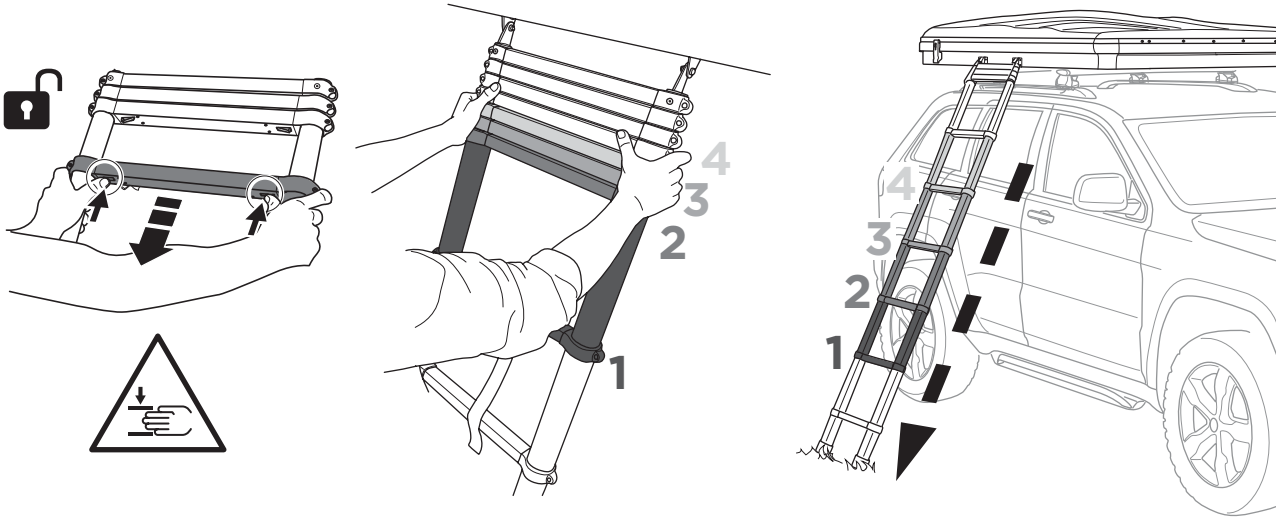

5

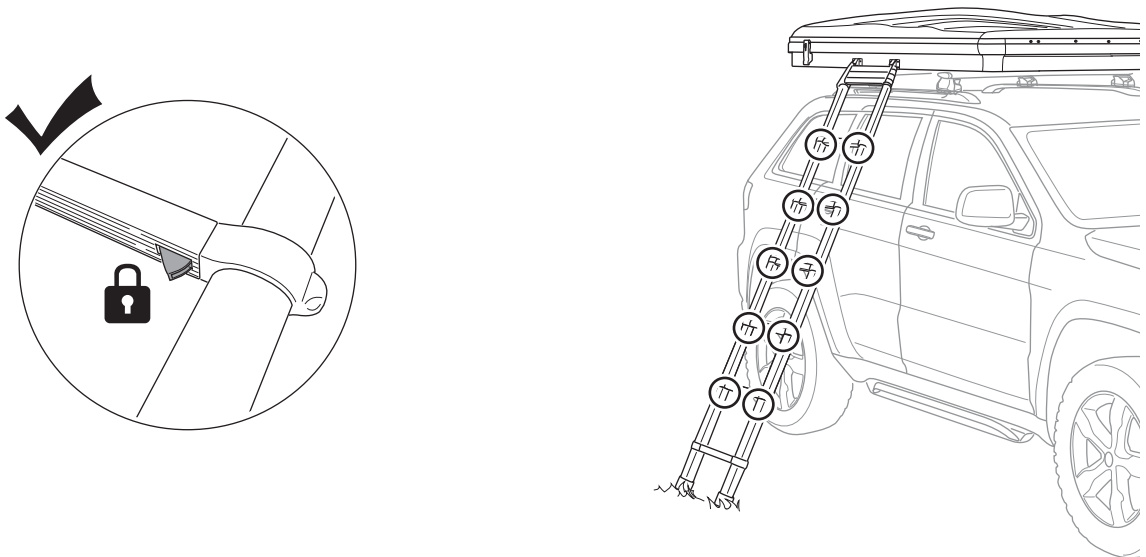

6

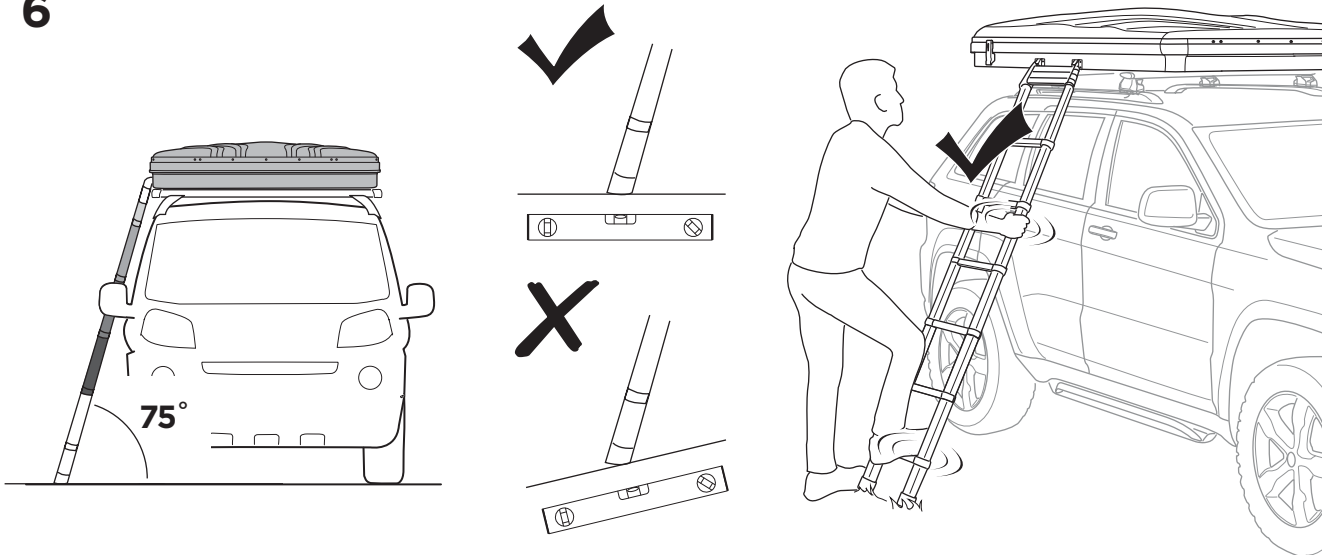

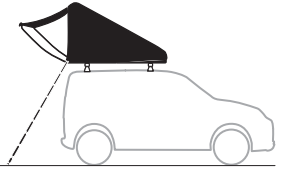

1

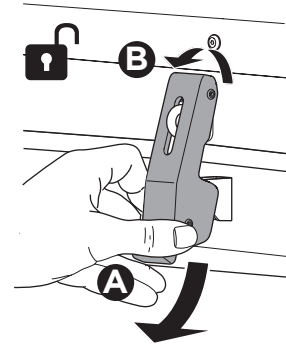
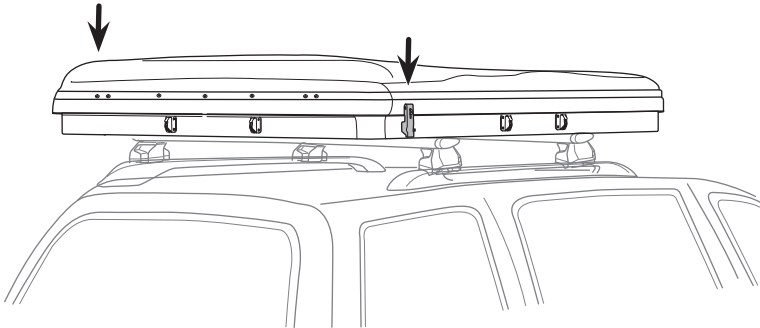

2

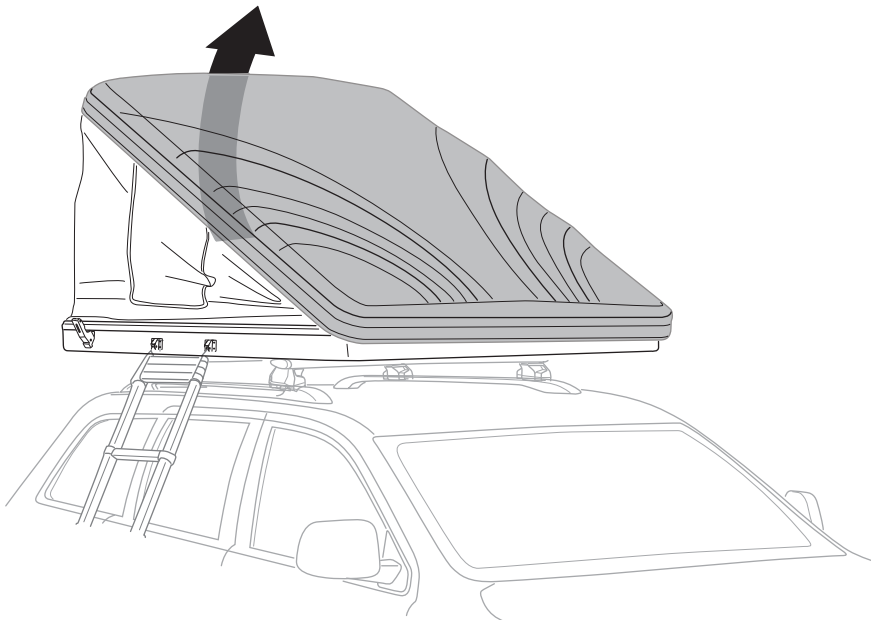

3

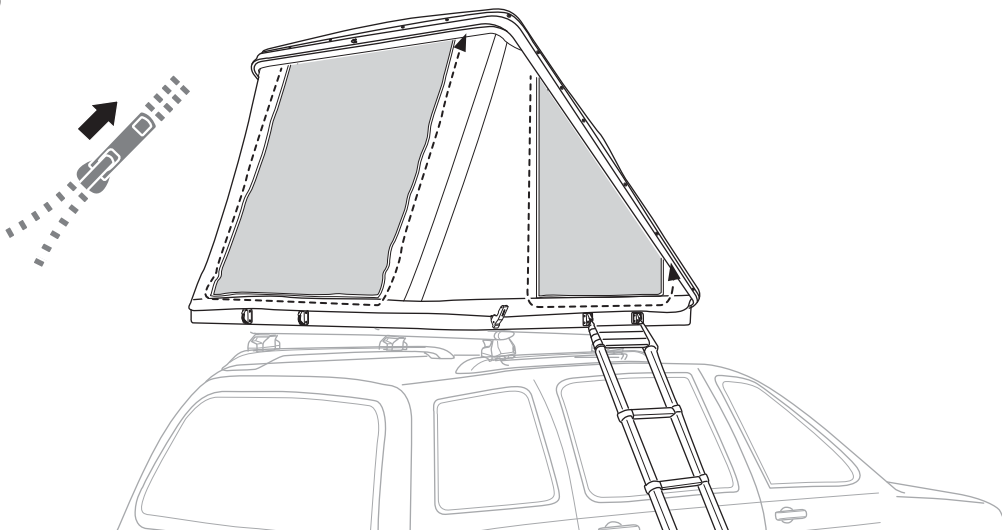

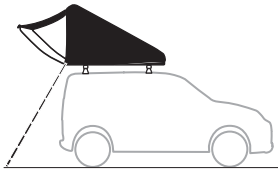

4

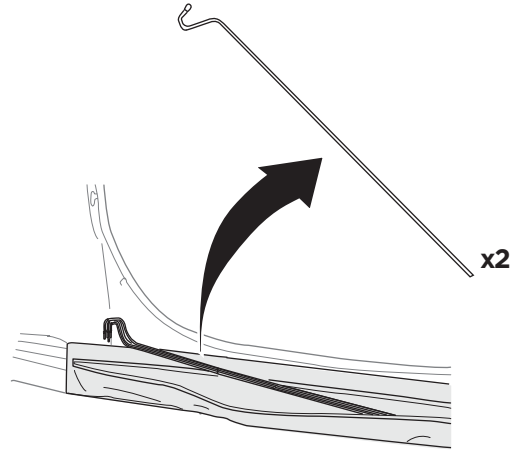
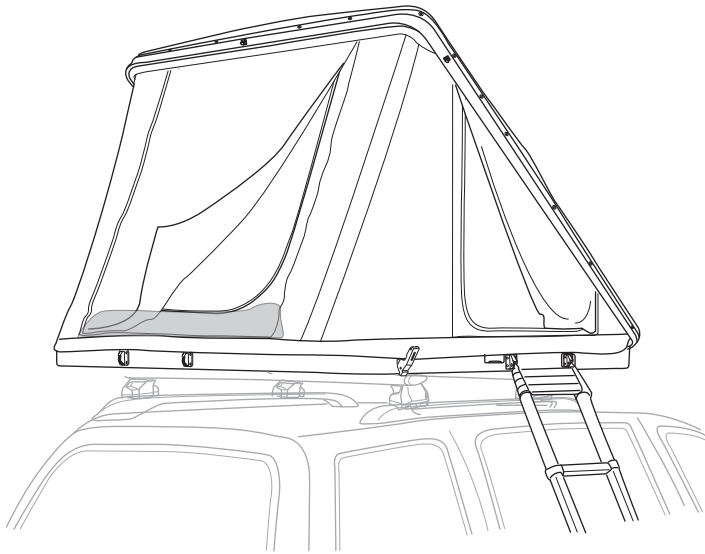

5

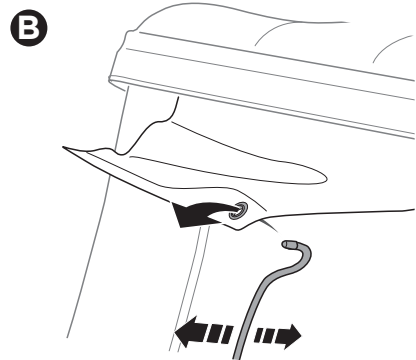
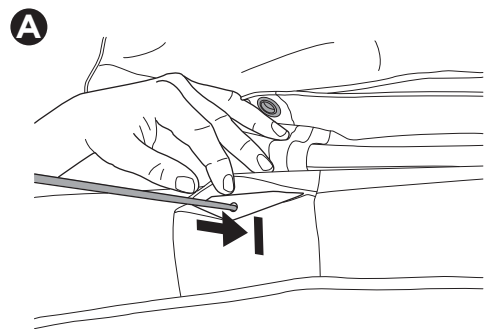
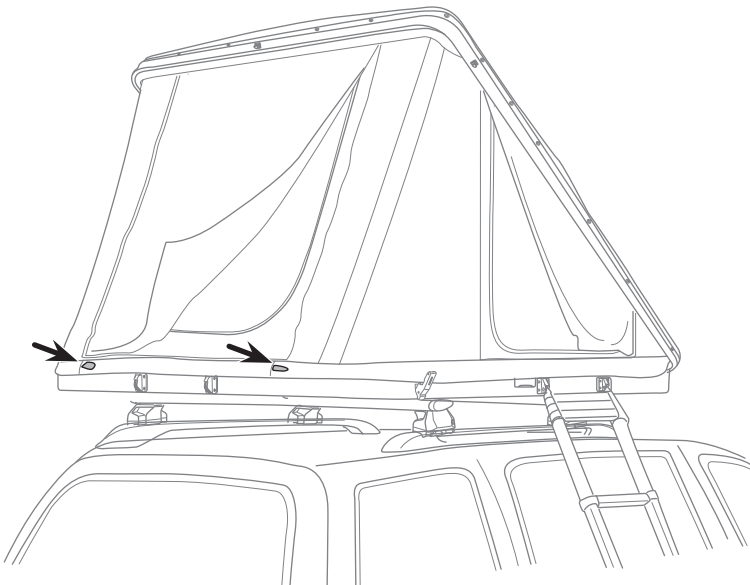

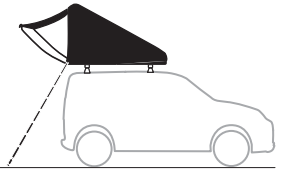

6

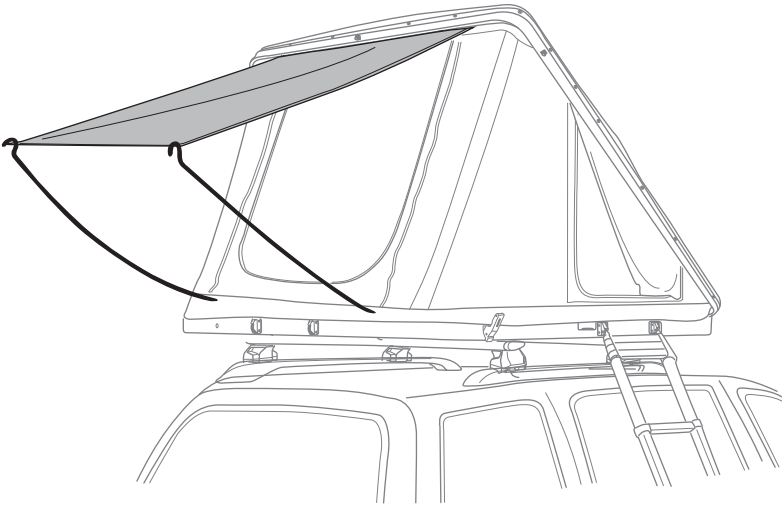

7

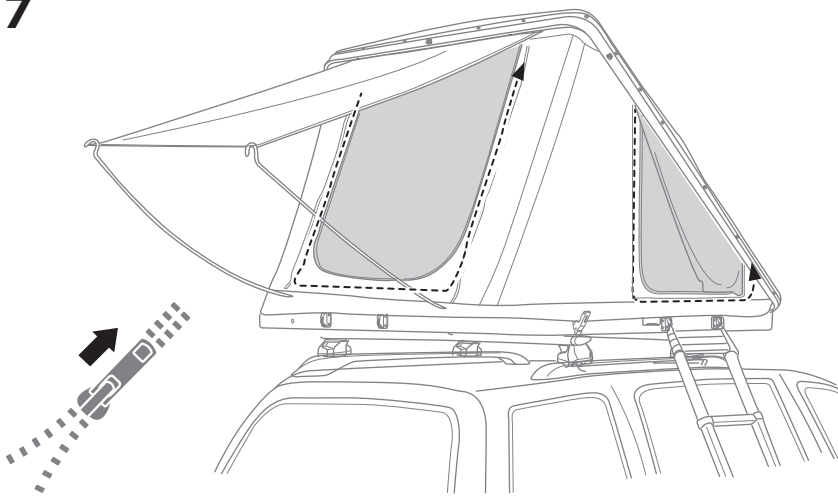

8

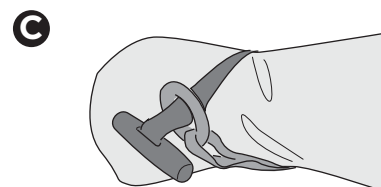
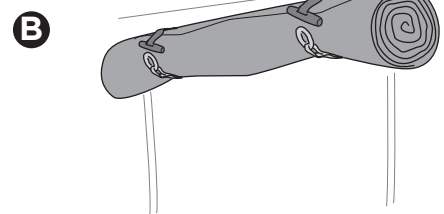
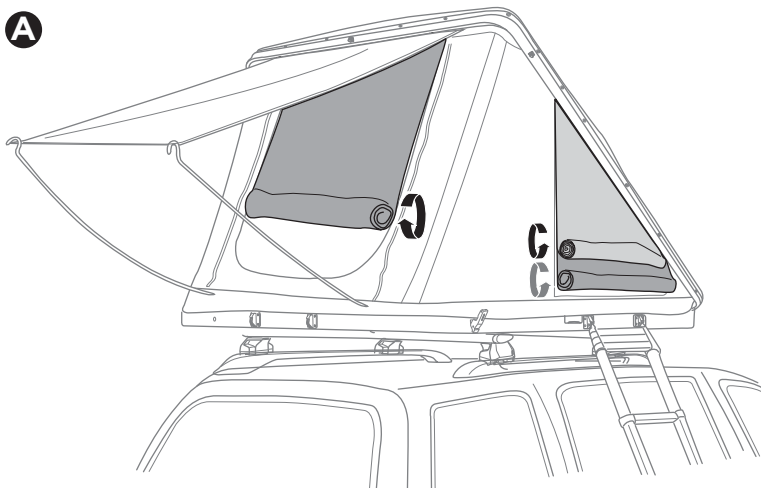

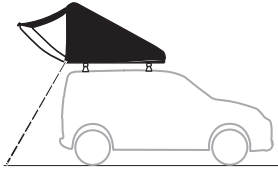

9

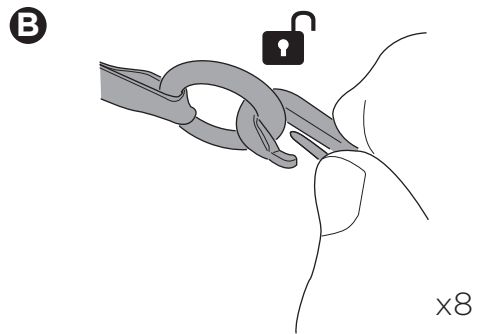
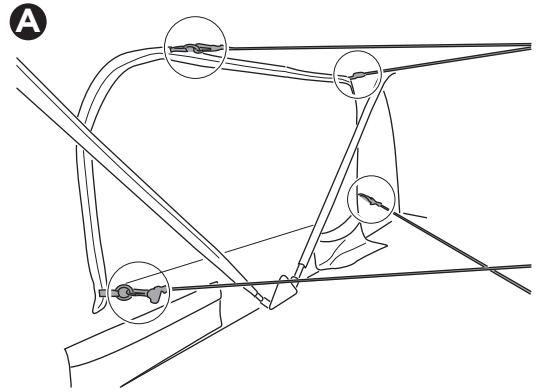
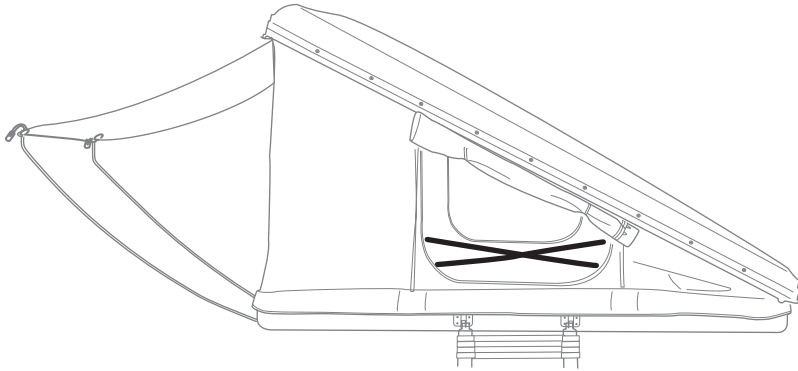
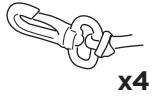

10

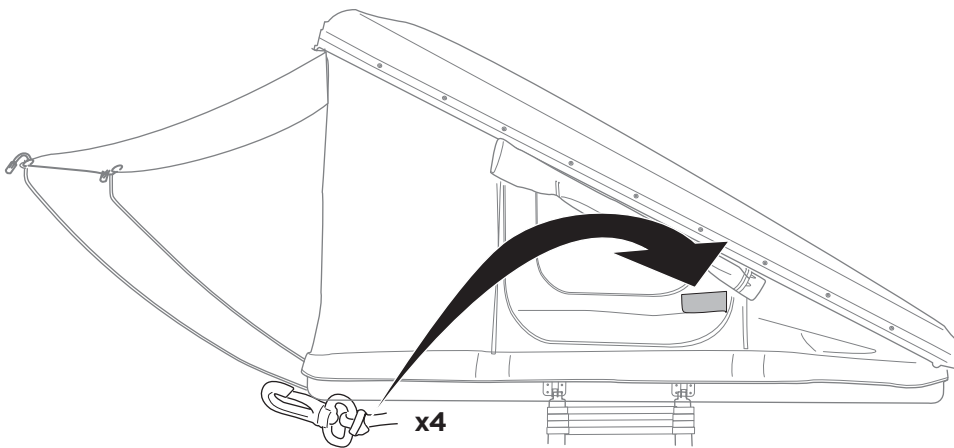

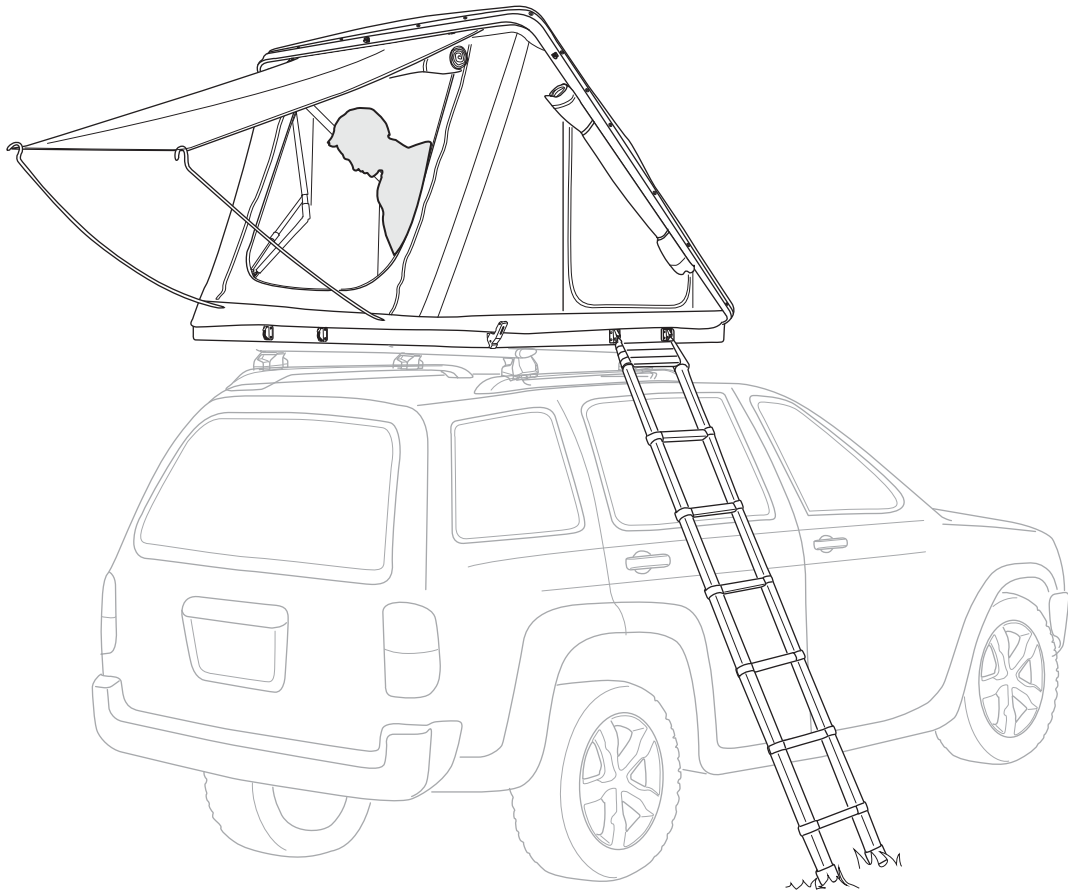
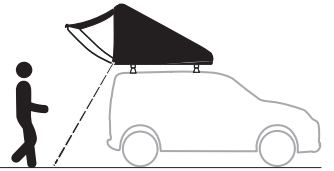



1

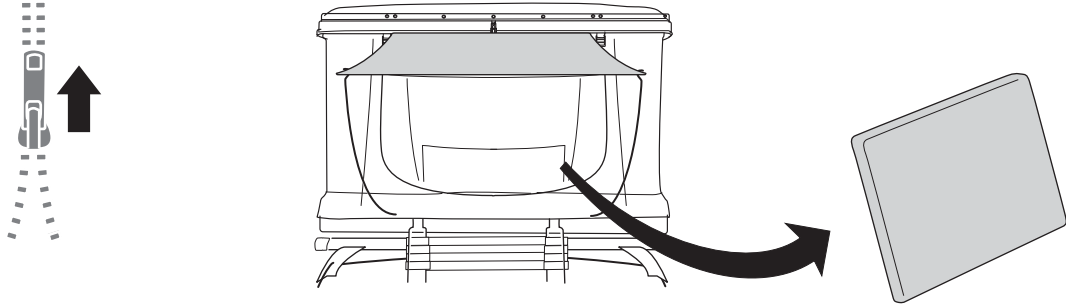

2

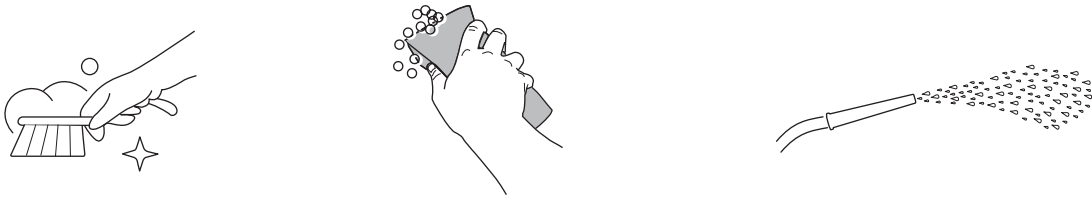

3

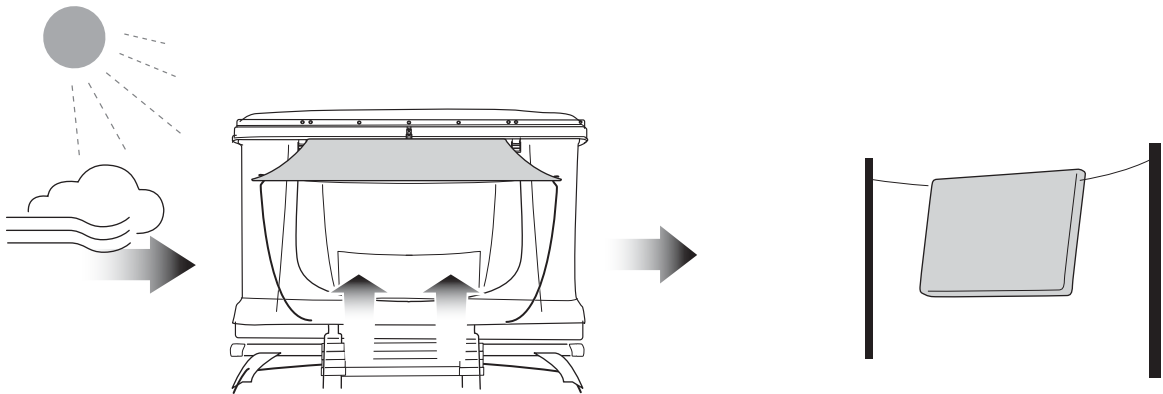

4

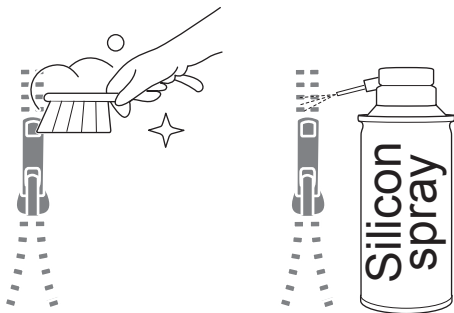

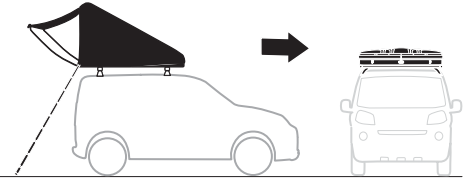

1

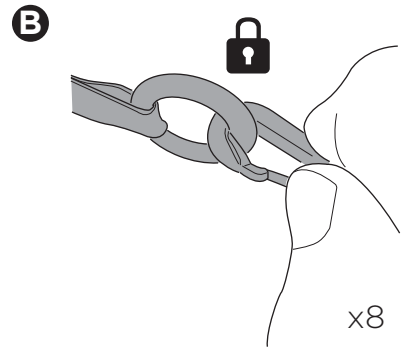
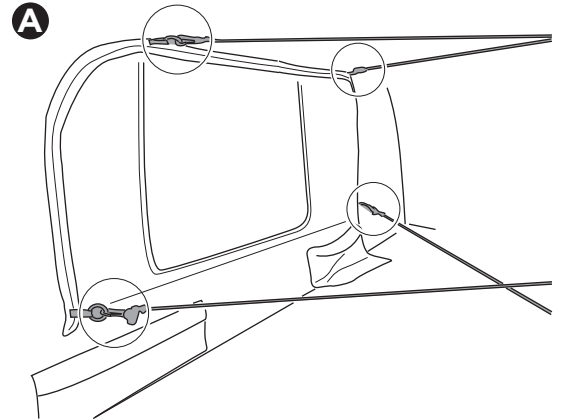
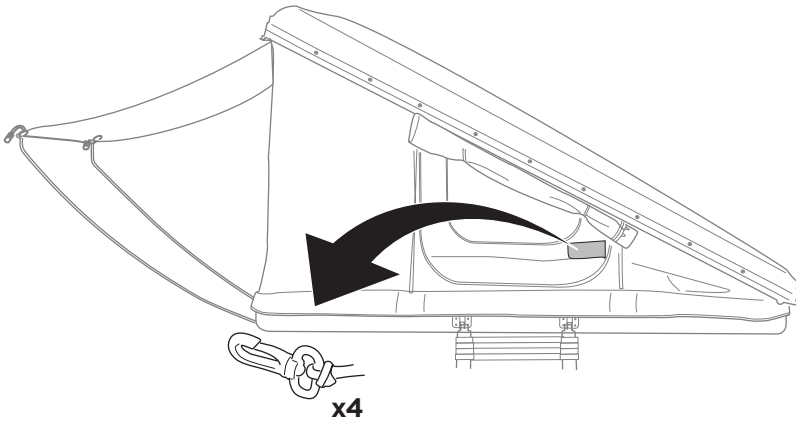

2

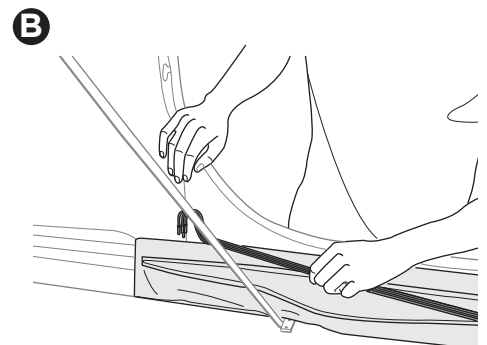
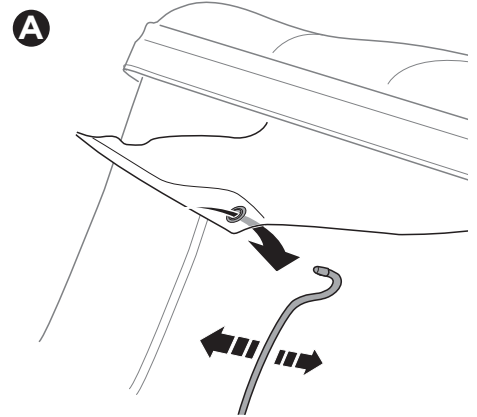
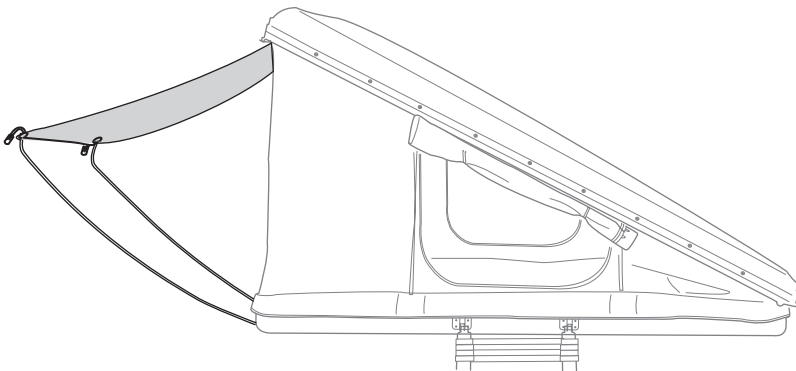

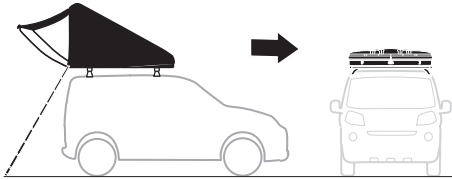

3

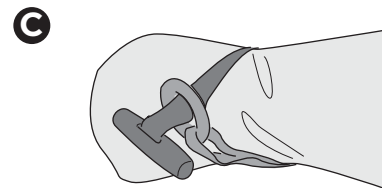
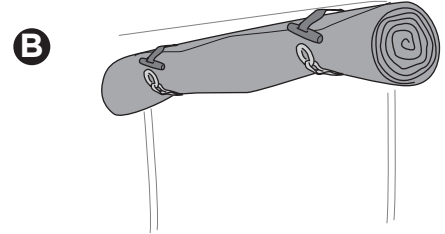
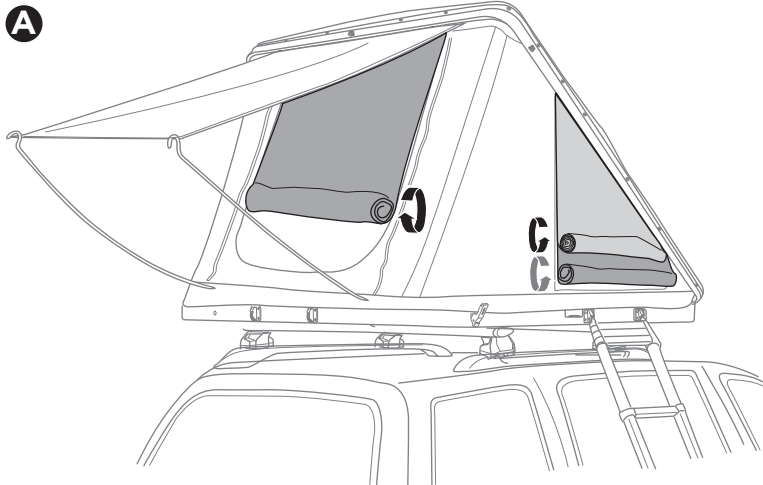

4

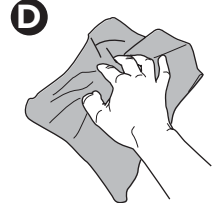
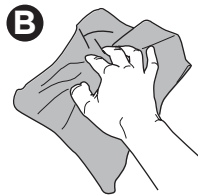
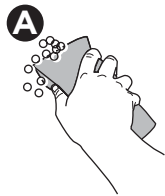
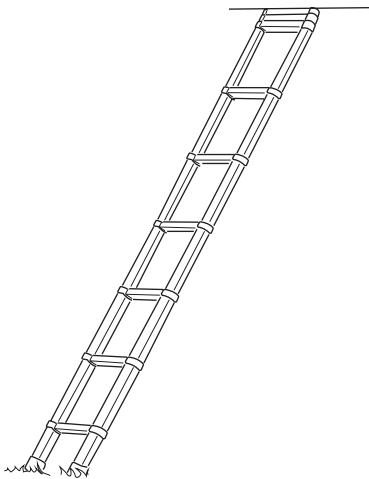

5

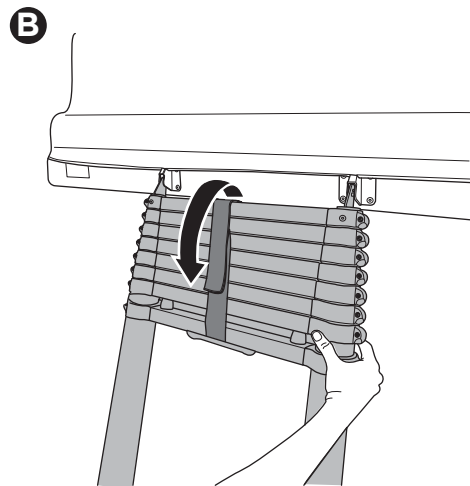
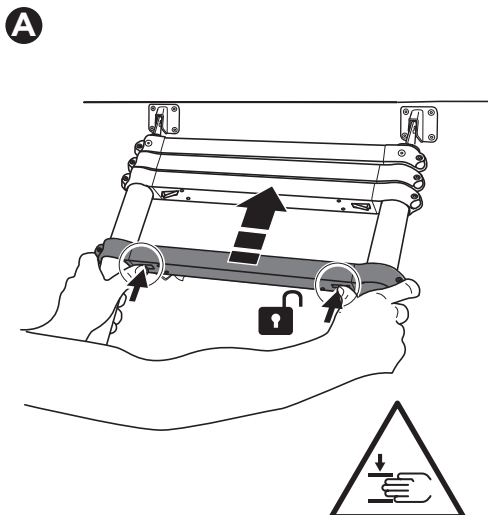

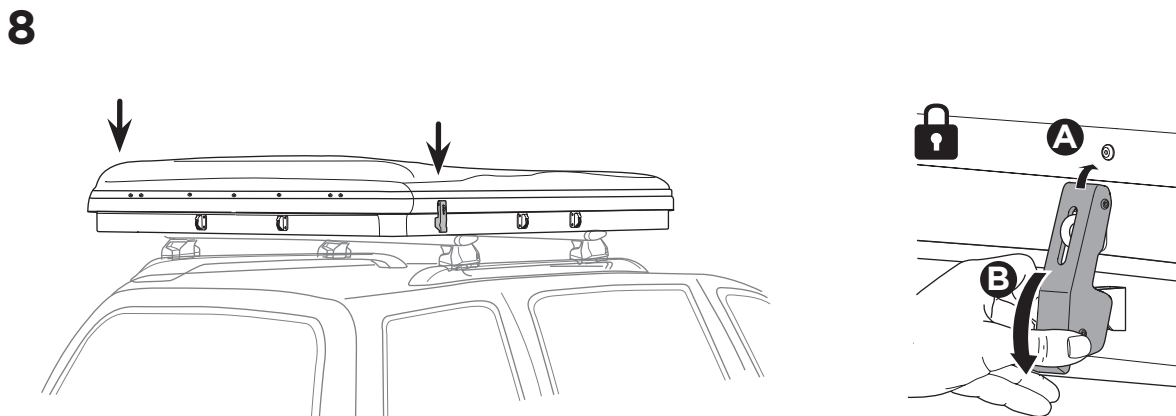
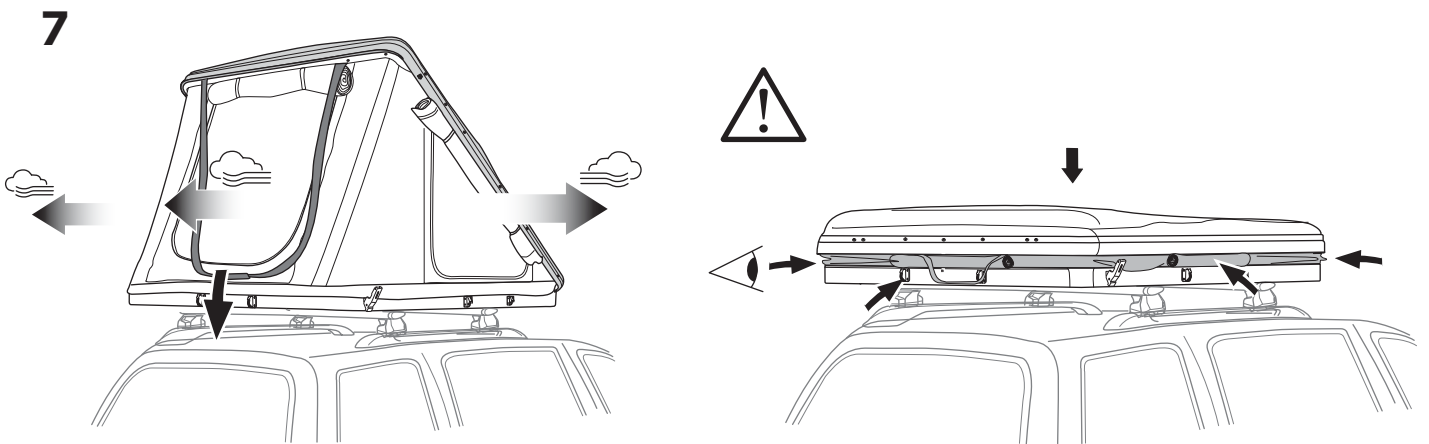
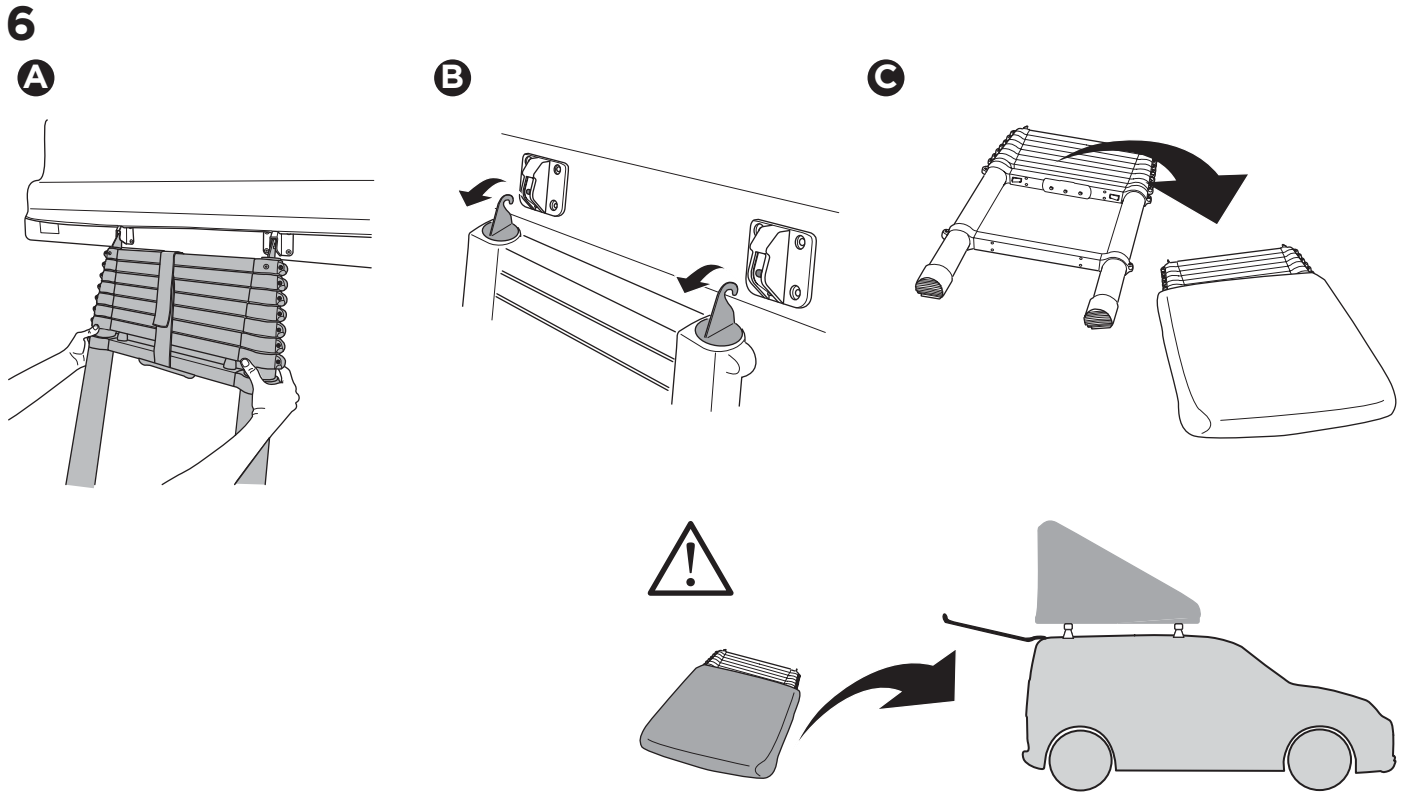
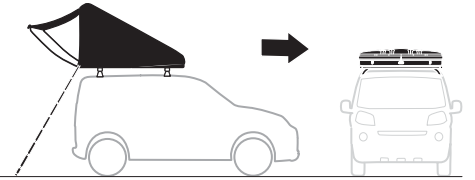

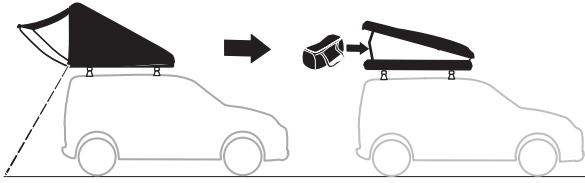

1

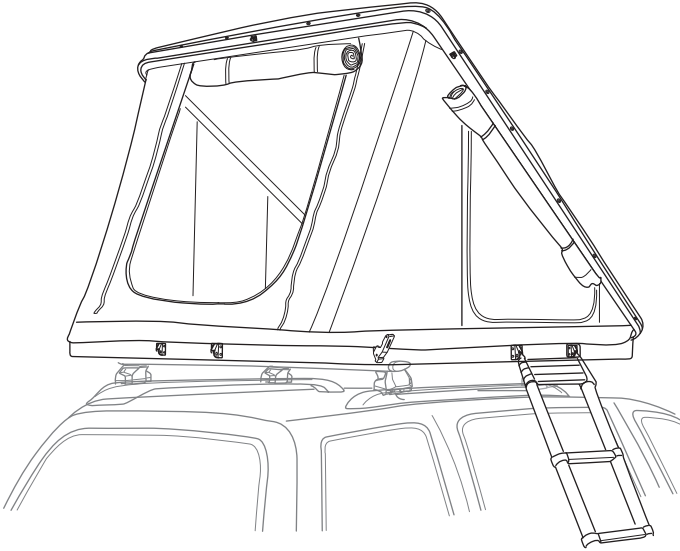

A

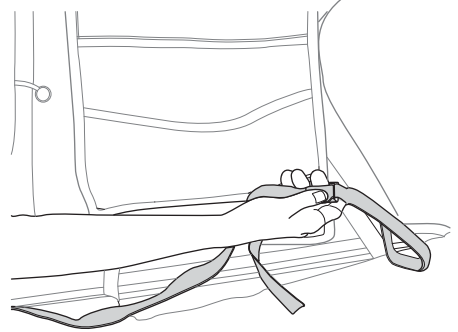

B

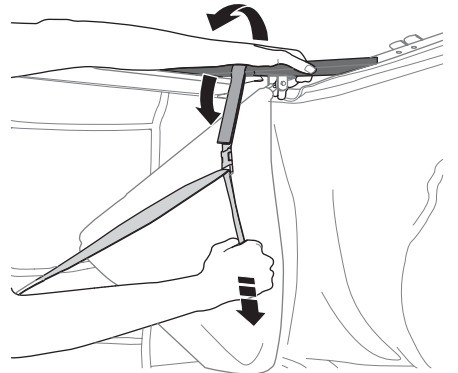

2

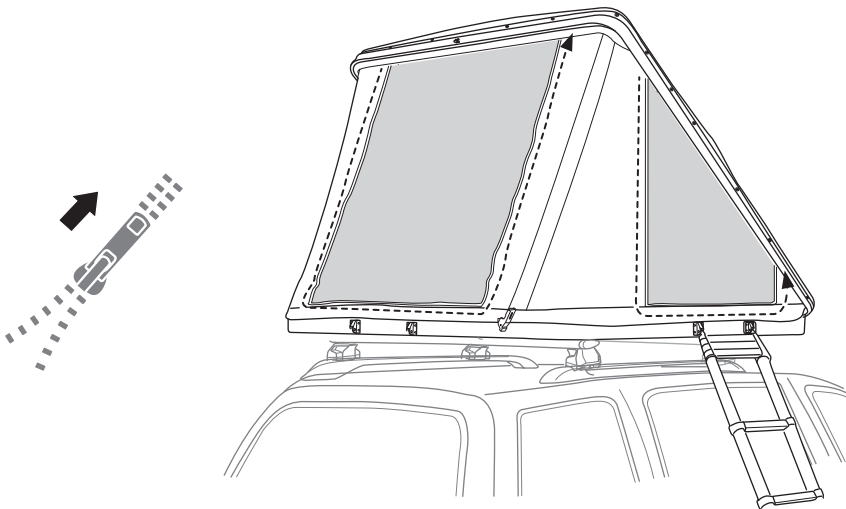

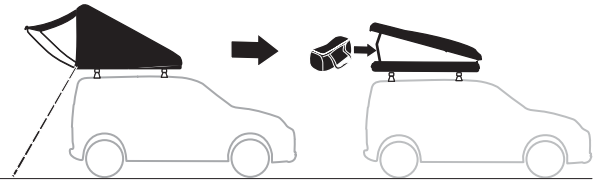

3

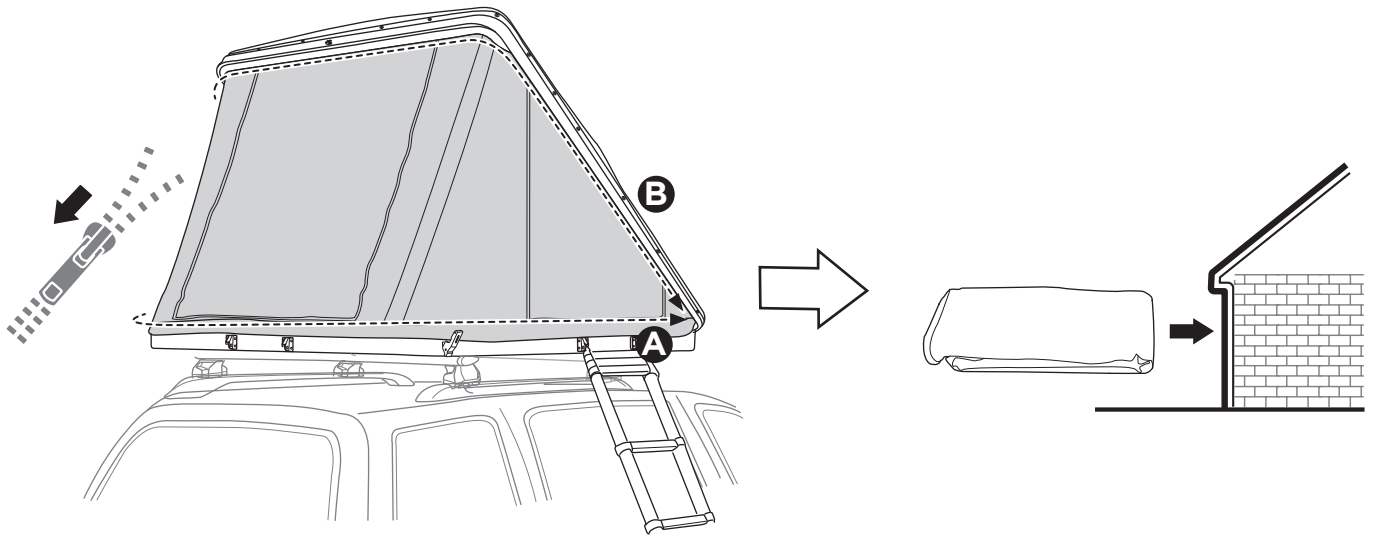

4

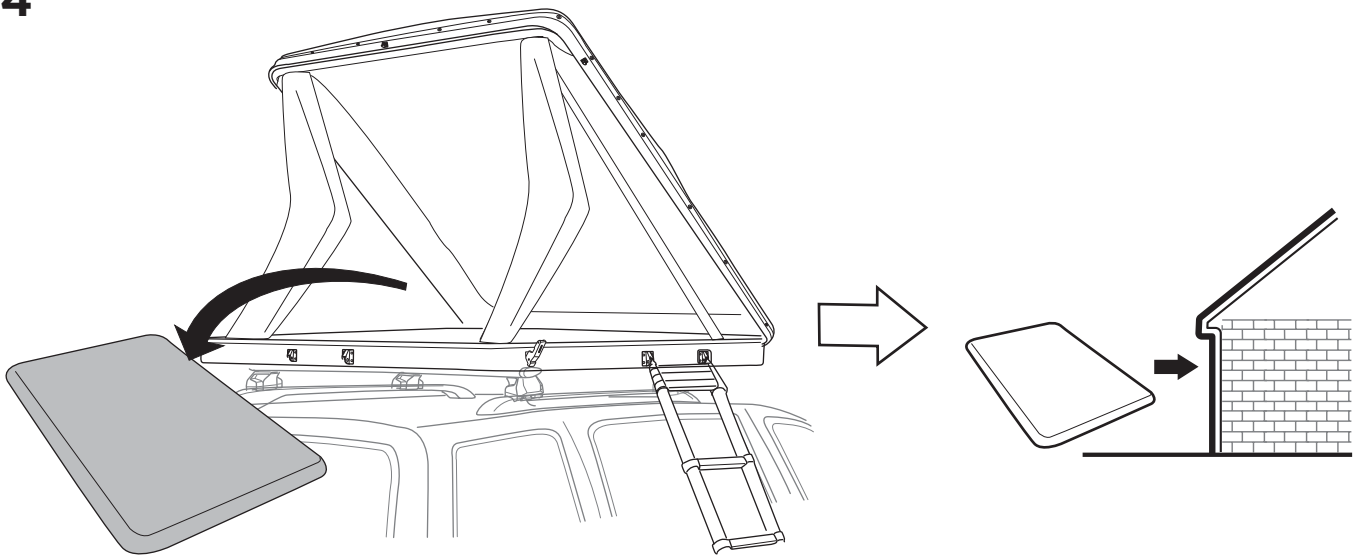

5

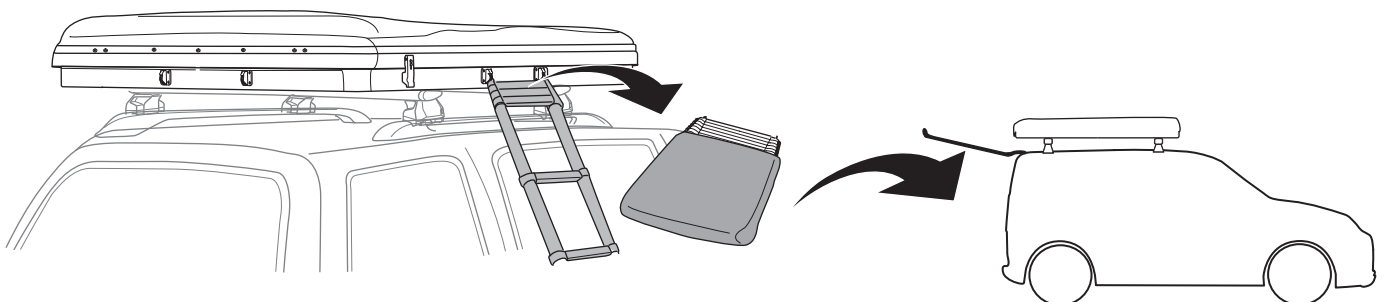

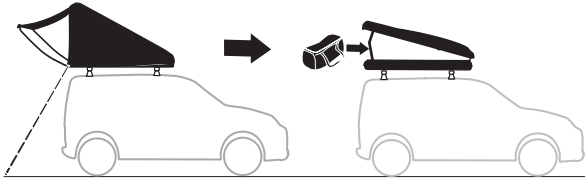

6

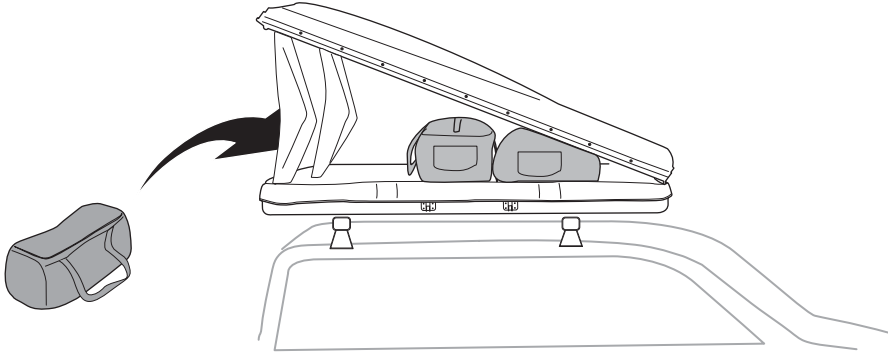

DO NOT exceed the maximum weight capacity of the roof rack or car roof. **EN**

NE PAS dépasser la capacité de charge maximale de la galerie de toit ou toit de voiture. **FR**

Überschreiten Sie NICHT die maximale Tragfähigkeit des Dachträgers oder Autodach. **DE**

NO exceda la capacidad de carga máxima del portaequipajes o techo de carro. **ES**

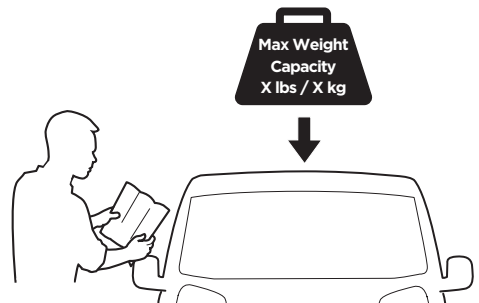
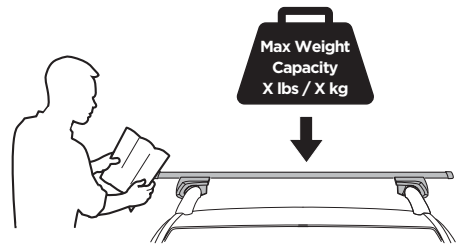

7

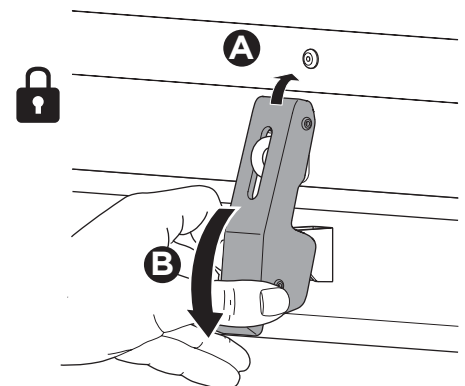
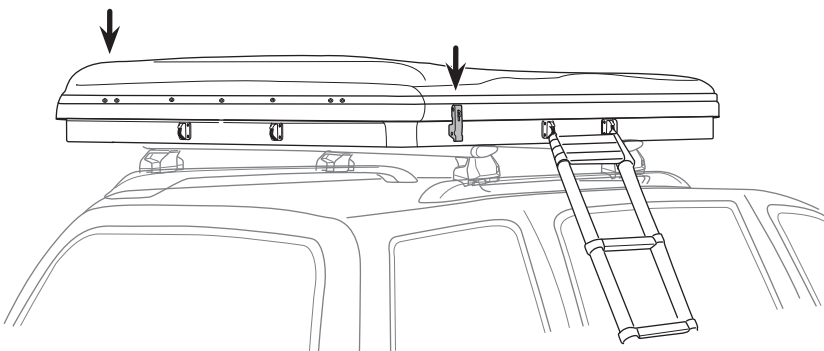

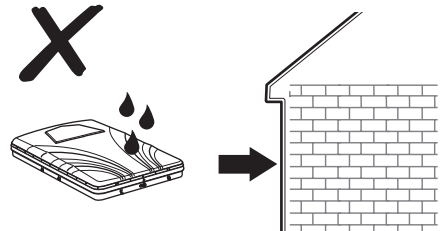
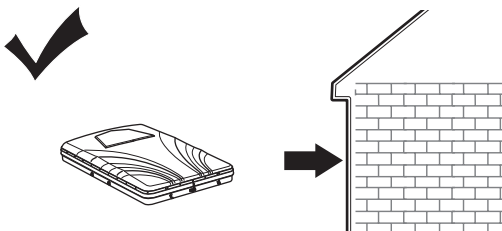
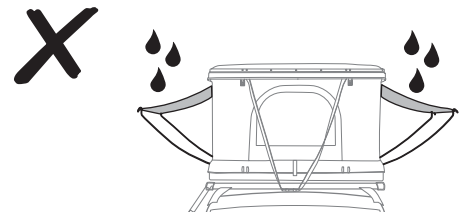
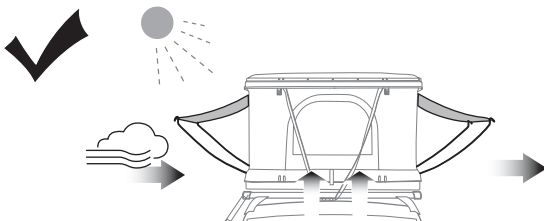
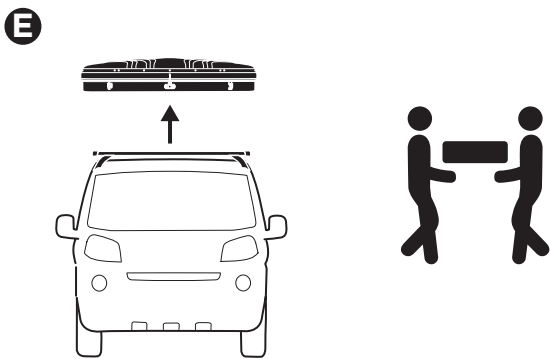
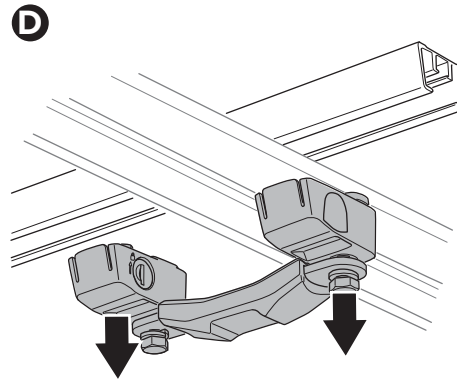
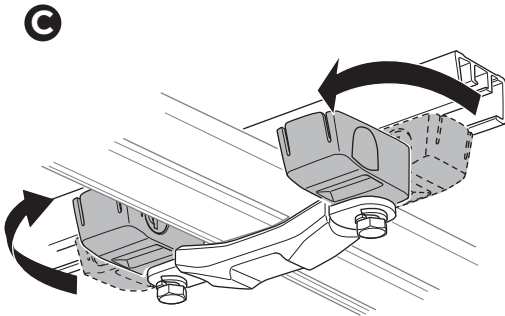
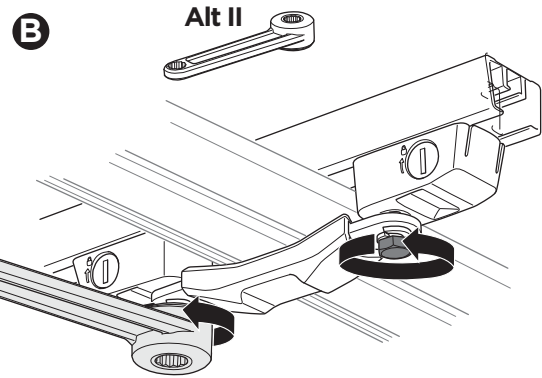
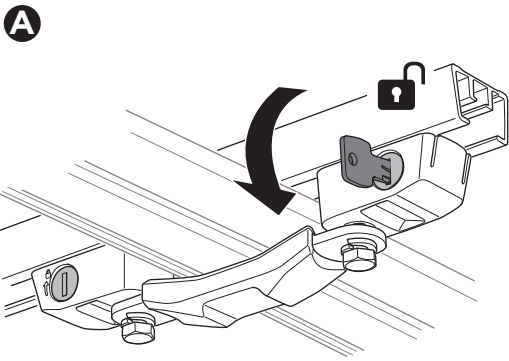
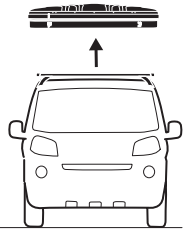

EN Accessories
FR Accessoires
ES Accesorios
DE Zubehör
NL Accessoires
PT Acessórios
IT Accessori
SV Tillbehör
DK Tilbehør
NO Tilbehør
FI Lisävarusteet
IS Aukabúnaður

ET Tarvikud
LV Piederumi
LT Priedai
RU Аксессуары
UK Аксесуари
PL Akcesoria
CS Příslušenství
HU Kiegészítők
RO Accesorii
SK Príslušenstvo
SL Dodatna oprema
BG Аксесоари

HR Dodatna oprema
EL Αξεσουάρ
TR Aksesuarlar
MT Aċċessorji

אביזרים **HE**
الملحقات **AR**

ZH (CN) 附件
ZH (TW) 配件
JA アクセサリー
KO 액세서리
TH อุปกรณ์เสริม
MS Aksesori

Thule Levelers 307617

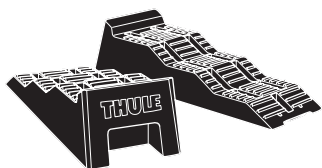

Thule Tent Table 901900



Thule Boot Bag Double 901702, 901705



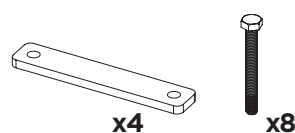

Thule Adapter Kit Xadapt 14

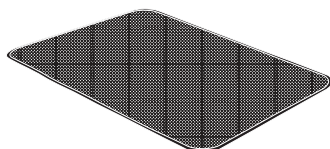

Thule Anti-Condensation Mat 901870

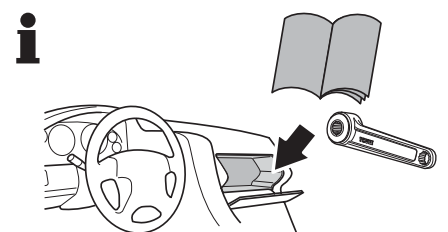



 Thule Sweden AB, Borggatan 5
335 73 Hillerstorp, SWEDEN

» PART OF THULE GROUP

 info@thule.com

© Thule Group 2022. All rights reserved.

 www.thule.com

5561698001